



light, photons, & beyond



STARS

**Summer
science camp**

4th annual

June 5 • 23, 2006

USF STARS: an NSF GK-12 Program

Camp Lessons

Name

Team



**Hillsborough County
PUBLIC SCHOOLS**
Excellence in Education

USF UNIVERSITY OF
SOUTH FLORIDA.

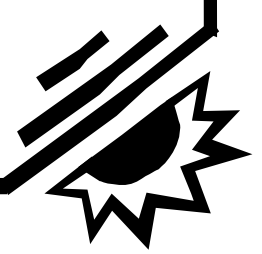

About STARS



USF STARS Team
Left to right, front
row:

Dr. O. Geoffrey Okogbaa, PI, Department of Industrial Engineering;
Souheil Zekri, Fellow, Dept. of Mechanical Engineering;
Ophir 'GG' Ortiz, Fellow, Department of Electrical Engineering; **Alfred Ogden**, Fellow, Department of Mechanical Engineering.
Second row: **Dr. Tapas Das**, co-PI, Department of

Industrial Engineering; **Tiffaney Mathis**, Fellow, Department of Chemistry;
Cheriese Edwards, Project Coordinator; **Adrian Defante**, Fellow, Dept. Chemical Engineering. **Last row:** **Kevin Young**, Fellow, Dept. Chemical Engineering; **Zoe Bethancourt-Seda**, Fellow, Department of Industrial Engineering; **Vishnu Nanduri**, Co-Project Manager, Department of Industrial Engineering; **Jorge Lallave**, Fellow, Department of Mechanical Engineering; **Caetano Cash**, Fellow, Department of Computer Science Eng.

STARS members not in picture:

Wandaliz Torres-Garcia, Recent Fellow, Department of Industrial Engineering; **Wilkistar Otiendo**, Co-Project Manager, Department of Industrial Engineering; **Dr. Grisselle Centeno**, co-PI, Department of Industrial Engineering; **Dr. Ashok Kumar**, co-PI, Department of Mechanical Engineering; **Dr. Louis Martin-Vega**, Dean and co-PI, College of Engineering; **Dr. Brenda Townsend**, co-PI, Department of Education; **Dr. Michael Churton**, co-PI, Department of Education; **Elizabeth Hunnicutt**, Science Coordinator, School District of Hillsborough County.



The USF Students Teachers And Resources in the Sciences (S.T.A.R.S.) program is a National Science Foundation (NSF) grant awarded to the University of South Florida to infuse higher-level science & math concepts in grades 3-5. We have partnered with 11 local elementary schools including, Berkeley Preparatory, Edison Elementary, Lawton Chiles Elementary, Robles Elementary, and Tampa Palms Elementary.

As an extension of the NSF initiative, the graduate students have organized a summer camp for elementary school kids throughout Hillsborough County. Students will participate in a series of lessons and activities that focus on aspects of light such as solar energy, photons, atoms and much more. Students will compete in an Olympiad in which they will design and construct a solar energy catching system. Culminating activities will include an awards ceremony on June 23, 2006 at 12 p.m..

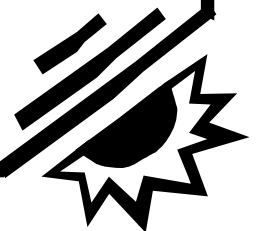

Table of Contents

Earth & Space.....	5
What do you know?.....	6
Stellar Light Year Travel.....	7
Life In Space.....	8
Hello Over There.....	9
Serving the Universe on a Paper Plate.....	16
What did you learn?.....	18
Processes That Shape the Earth.....	19
What do you know?.....	20
Glaciers.....	21
Lightning & Thunder.....	26
Topo Maps.....	29
Simulators.....	36
What did you learn?.....	39
Force & Motion.....	40
What do you know?.....	41
Vectors & Scalars.....	43
Water Force & Pressure.....	50
Simulations.....	55
Aqueducts.....	59
Solar Cars.....	63
What did you learn?.....	69

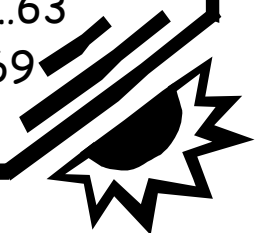
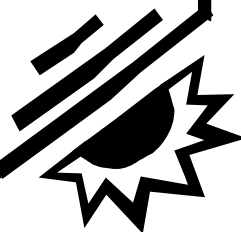

Table of Contents

Energy.....	71
What do you know?.....	72
Energy Regulators.....	73
Harnessing the Wind.....	77
Heat.....	80
What did you learn?.....	83
Nature of Matter.....	84
What do you know?.....	85
Reactions & The Messy Lab.....	86
Electron Light.....	92
Presence of Luminescence.....	96
The Light Microscope for the Young Scientist..	99
What did you learn?.....	106
Processes of Life.....	107
What do you know?.....	108
Photosynthesis.....	109
Hurricanes.....	112
DNA Bites!.....	113
The Skin & UV.....	116
What did you learn?.....	122





Earth & Space

What do you know?

<p>How does the sun produce energy?</p>	<p>How do we measure how far a star is from Earth?</p>
<p>Name the 9 planets.</p>	<p>What is an eclipse?</p>
<p>How many phases does the moon have?</p>	<p>What is a radio wave?</p>





Stellar Light Year Travel

Objective:

- Understand that planetary objects such as stars, planets, asteroids are very large distances apart
- Problem solve how light intensity can be used to measure the distance between two objects

Activity Overview:

In teams of 2 to 3 students will determine the luminosity of the sun using a 200-watt light bulb. Using a null photometer, students will learn to measure the apparent brightness of a luminous object and the distance to the object. A small light source with the output of one-millionth of a watt simulates a star in the sky whose distance to the star can be estimated.

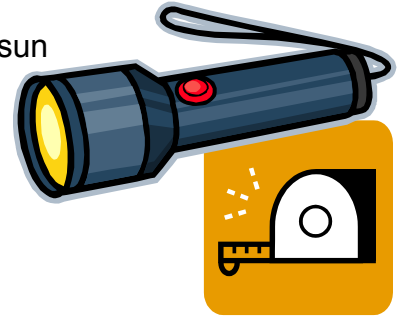

Vocabulary Words

Star
Constellation
Galaxy
Universe
Light Year
Nuclear Fusion
Magnitude

Materials

Light Measurement and Stellar Distance Kit (www.starlab.com)

- 1 paraffin blocks
- 1 foot-long pieces of optical fiber
- 1 200-watt lamp
- 1 lampholder
- 2 rubber bands
- 1 flashlight with batteries
- 1 25' roll of aluminium foil

**Objective**

- Students will learn various facts about the different planets comprised of our solar system

Activity Overview

In teams of 2 students will choose from a grab bag of 8 planets and the sun and create a diorama of life on that planet using various materials. There will research certain facts about their respective planet and share the information in a short presentation to the other students. A large compare and contrast chart will be constructed of all various facts about the planets.

Materials

1 piece of foam board
Various arts and crafts supplies
Imagination



ACTIVITY:

"Hello Over There"



Objective

- Demonstrate with light beams how Amateur Radio satellite and repeaters send and receive signals
- Problem solve how a beam of light can be directed around a barrier

Activity Overview

This activity will allow students to simulate radio waves being transmitted and received using repeaters. Earth will be observed so students will understand why this method of communication is needed. In teams of four, students will problem solve to send a beam of light from one side of a barrier to the other. They will learn the path that light follows and how it reacts when a smooth, shiny surface (mirror) is placed in its path. Amateur Radio vocabulary will be introduced. Students will complete a Data Collection Sheet detailing methods used to solve a problem. Older students will predict where the light waves will be positioned on the other side of the barrier.

Materials

For each team of 4:

- 1 flashlight
- 1 mirror
- 1 chair or desk to act as barrier

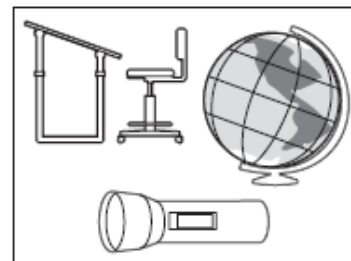

- 1 piece of white paper
- Globe or map of Earth
- Data Collection Sheet

Science Standards

- Science as Inquiry
- Science and Technology
- Abilities of Technological Design

Technology Standards

- Technological Knowledge
 - Technological Concepts and Principles
- Technological Processes
 - Utilizing and Managing Technological Systems
- Technological Contexts
 - Informational Technology

Mathematics Standards

- Problem Solving
- Communication
- Geometric and Spatial Relations

Timeframe: 30-45 minutes

When looking at a relief map of the Earth, one cannot help but notice that Earth is not a flat plain. There are many valleys and mountain ranges. When standing on an ocean shoreline, Earth appears flat. But we know that Earth is round. Pictures sent from satellites and orbiting spacecraft have allowed us to see our round Earth. Since radio waves travel in a straight line, how then can we send a signal to the other side of a barrier and beyond? Some radio signals, called **direct waves**, travel in a straight direction or line-of-sight. These signals cannot bend or "jump" over a barrier

such as a hill or mountain range. They are also unable to curve around Earth. The signal from a radio on one side of the hill is transmitted to the other side by a repeater positioned on the top of the barrier. A **repeater** receives a signal on one frequency and simultaneously sends, or re-transmits (repeats) it on another frequency to a radio on the other side of the barrier thereby extending the range of the re-transmitted signals.

The frequency it receives on is the **input frequency**, and the frequency it transmits on is the **output frequency**. Often located atop a tall building or high mountain, VHF and UHF repeaters greatly extend the operating range of Amateur Radio operators using mobile and hand-held transceivers. When a transmitter and receiver are combined into one box, it becomes a transceiver and can send and receive signals. If a repeater serves an area, it's not necessary for everyone to live on a hilltop. But you have to be able to hear the repeater's transmitter and reach the repeater's receiver with your transmitted signal.

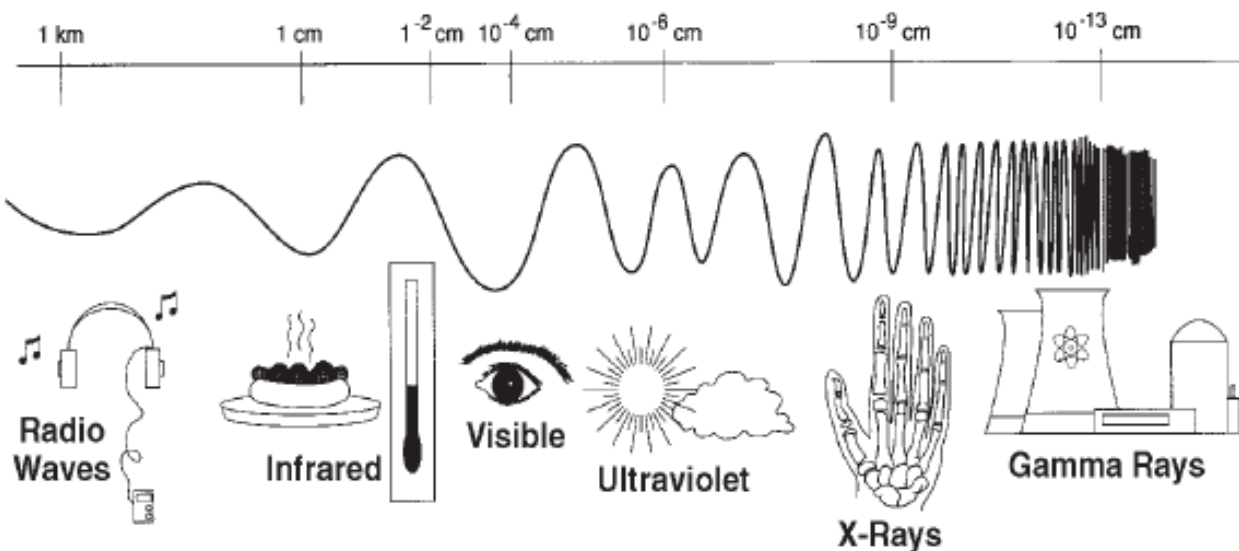

Procedure

1. Share background information with students. Show globe or relief map of Earth. Have students write or draw their observations of Earth on the Data Sheet. Discuss these observations orally.
2. Gather students together around a barrier (chair, desk, etc.) Explain to students that the barrier represents a very tall hill or mountain range.
3. Show flashlight, mirror, and piece of paper. Discuss the properties of each, how they are used in our daily lives, and any prior knowledge students may have about light beams and how they travel. The flashlight beam represents radio waves, the mirror represents the repeater on top of a hill, and the piece of paper represents the radio on the other side.



HINT: Cover the flashlight with a piece of paper that has a small, vertical slit cut in the middle. This will create a narrower light beam.

Discuss vocabulary words and have students write definitions to those words on the Data Collection Sheet.

4. Tell students they will work in teams of four. The problem they must solve is to **devise a way to send a beam of light to the other side of the barrier going over the top of the barrier**. The light must travel from the flashlight held touching the floor on one side of the barrier to the piece of paper placed on the floor on the other side of the barrier. Remind them that they must go over the barrier. They will need to document the steps they take in the Data Collection Sheet.

After a group discussion, make sure students understand the task. Give ample time for students to work in their groups to write the happen, solve the problem, and write down the information on the Data Collection Sheet. Have each group share their procedure with the class. Allow the class to ask questions and make suggestions.

5. As a follow up to the initial activity, each group can take what they have learned from watching the other groups and the suggestions they have been given and improve their procedure.



Name _____

Date _____

Data Collection Sheet

Name _____

Group Names _____

Date _____

Observations of Earth

Problem to Solve



Repeater

Input Frequency

Output frequency

Name _____

Date _____

Data Collection Sheet

What Materials Did You Use? _____

What Did You Do? _____

What Did You Observe? _____

What Did You Learn? _____



Serving the Universe on a Paper Plate

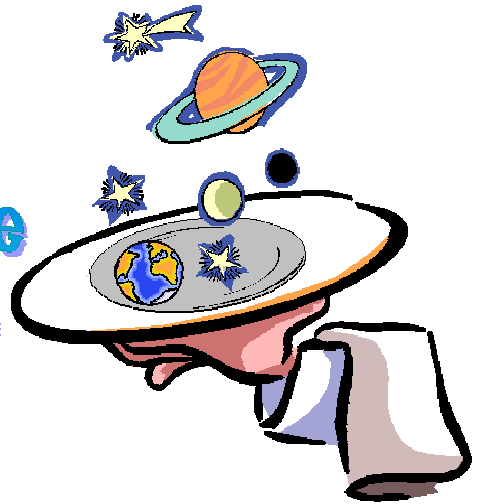

Objective

- Demonstrate the complete cycle of the moon phases
- Understand the position of the moon in reference to the position and rotation of the Earth

Activity Overview

This activity will allow the students to fully understand the moon's orbital cycle by dividing the cycle into several segments or phases. By engaging the students in this activity, the students will become familiar with phases of the moon, and will be able to explain the reasons for the lunar phases depending on the orientation of the sun, moon, and Earth.

Vocabulary Words

New Moon

Full Moon

Waxing Crescent

Waning Gibbous

First Quarter

Third Quarter

Waxing Gibbous

Waning Crescent

Materials

Oreo Cookies

1 Paper Plate

1 Pencil

Peanut Butter or Cake Icing



Procedure

1. Half and scrape Oreo® cookies to illustrate moon phases. Then, arrange cookies on plate's perimeter around a central Earth.
2. After twisting apart bite-size Oreo® cookies, students scrape off the cream to simulate the eight different moon phases.
3. Have a teacher or volunteer use cake frosting or Peanut Butter to "glue" the moon phases onto the paper plate. Peanut butter (as glue) works well for the short term, but in time it causes the plate to get greasy under the cookies.
4. Dispose of the Oreo cookie scraps. Use you imagination!
5. Demonstrate to the classroom what the students have learned.

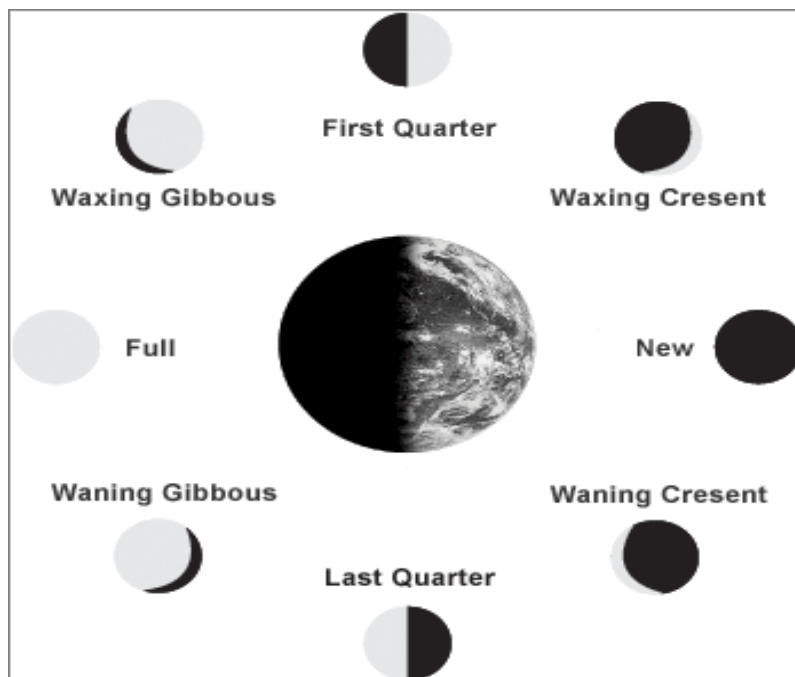
**Discussion Questions**

1. What views do you think astronauts have of the Earth and moon as they orbit Earth?

2. Would the moon phases change if the moon revolved around the Earth in the opposite direction? How?

Reference: <http://analyzer.depaul.edu/paperplate/pveclipse.htm>

Earth & Space

What did you learn?

How does the sun produce energy?	What 4 things determine the apparent brightness of a star?
Name the 2 largest planets in our solar system.	Name 4 different phases of the moon?
Name the two types of eclipses.	How do amateur radio satellites and repeaters send and receive signals?





Processes that shape the Earth

What do you know?

What is a model?

What is a simulation?

Why do we see lightning before we hear thunder?

What do topographic or "topo" maps show us?

How are glaciers formed?

How does a volcano create a rapid land change?



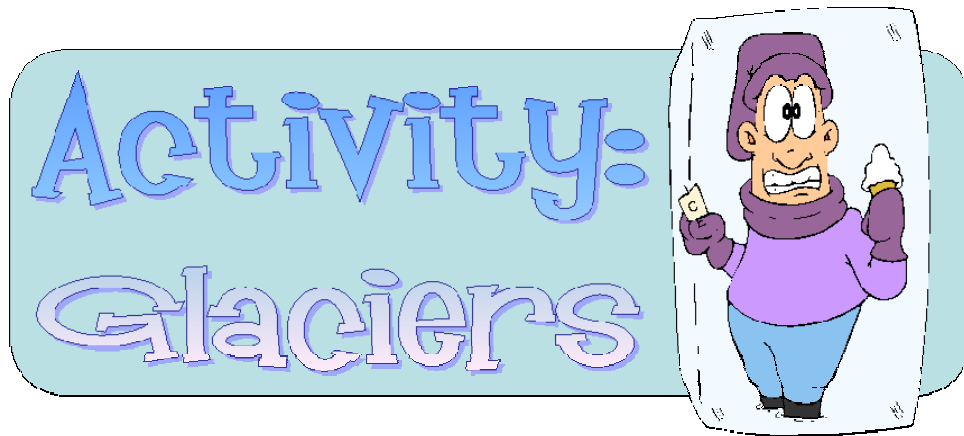

What is a Glacier?

Glaciers are large masses of snow, ice, sediments, rock and water that accumulate in great quantities and begin to flow outwards and downwards under the pressure of their own weight.



Glaciers form when yearly snowfall in a region far exceeds the amount of snow and ice that melts in a given summer. As the snow collects over many years, an ice field forms. Ice flows down the valleys and slopes of the mountains to the lower elevations, and glaciers are born.

Types of Glaciers

There are two main types of glaciers: **alpine glaciers**, which are found in mountain terrains, and **continental glaciers**, which are associated with [ice ages](#) and can cover large areas of [continents](#).

A **temperate glacier** is at the melting point throughout the year with internal and basal water. **Polar glaciers** are always below the

freezing point. A variety of Glaciers are found in different settings like mountain, valley, piedmont, cirque, hanging, and tidewater glaciers. **Tidewater glaciers** are glaciers that flow into the sea. As the ice reaches the sea pieces break off, or calve, forming [icebergs](#). Most tidewater glaciers calve above sea level, which often results in a tremendous splash as the iceberg strikes the water.

Glacial Motion

The glacial ice is made up of layers of molecules stacked on top of each other, with relatively weak bonds between the layers. When the stress exceeds the inter-layer binding strength, the layers start to slide past each other. Glaciers start leaving an impressive footprint on the landscape, carving the rock as they retreat. In addition, Glaciers could flood the seacoasts as a legacy of their retreats, causing many ecological changes on the landscapes around the glacier's edge.

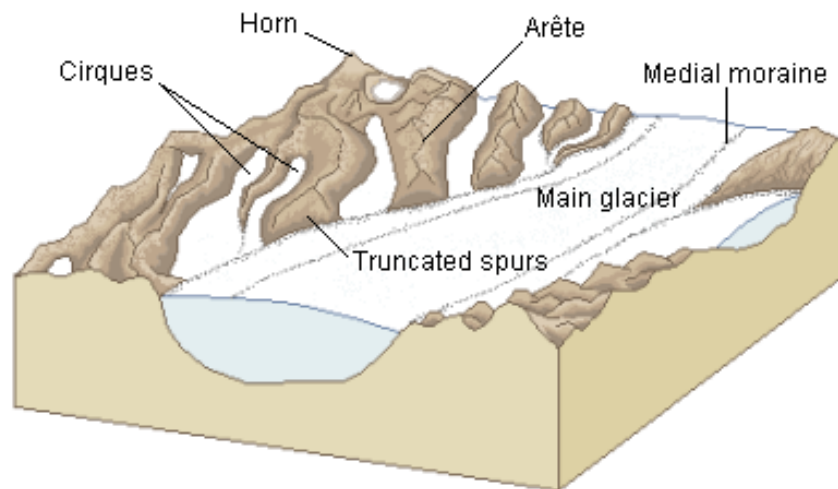

Anatomy of a Glacier

Materials Needed

Recipient bowl

2 plastic cups of 20oz

2 stopwatches

4 textbooks

Water

Gravel

Sand

Twigs

Freezer space

Wooden board

2' feet length, 3/4" thick, 6" wide

Procedure:

1. Pour water into the containers until they are half full.
2. Add different amounts of twigs, rocks and soil to one of the cups.
3. Place both containers in a freezer until frozen.
4. Once this is done take the containers outside and remove them from the ice from the cups.
5. Lean the wood against the textbooks to make a slope.
6. Place both blocks at the top of the board.
7. Time and record how long it takes for each to reach the bottom of the board.
8. Record what happens as the ice melts.



Observation Data sheet (What do you see?)

Time (min)	Observations
2	
5	
8	
10	
12	

CONCLUSION

1. How does sunlight and heat affect the Glaciers?

2. If the blocks were heavier, would it make a difference in the length of time it takes them to get to the bottom of the board?

3. Which block took longer to go down the slope?

Name _____

Date _____

4. How would a huge mass of ice move?

5. What could the moving ice body leave behind?

6. What happened to the wood as each block went down?



What is lightning?

Lightning is a bright flash of electricity produced by a thunderstorm. Lightning is an electric current.

What causes lightning?

Lightning is caused by collision of electric charges. In a calm sky, the positive and negative charges are evenly dissipated in the atmosphere. Therefore, a calm sky has a neutral charge.

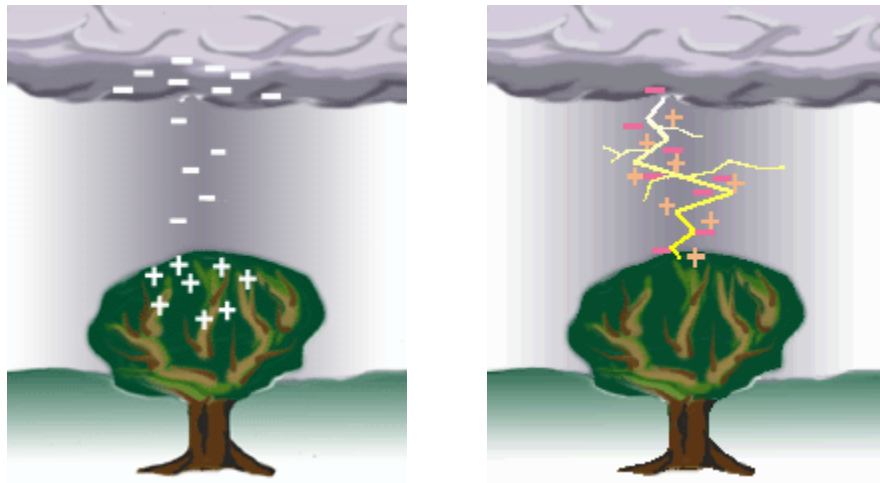

What causes thunder?

Thunder is caused by lightning. When a lightning bolt travels from the cloud to the ground it actually opens up a little hole in the air, called a channel. Once then light is gone the air collapses back in and creates a sound wave that we hear as thunder.

Thunderstorm Formation

Most thunderstorms form by a special cycle. This cycle has three stages: the Cumulus Stage, Mature Thunderstorm Stage, and Dissipating Stage. Click on each image below to learn more about how each cycle works.

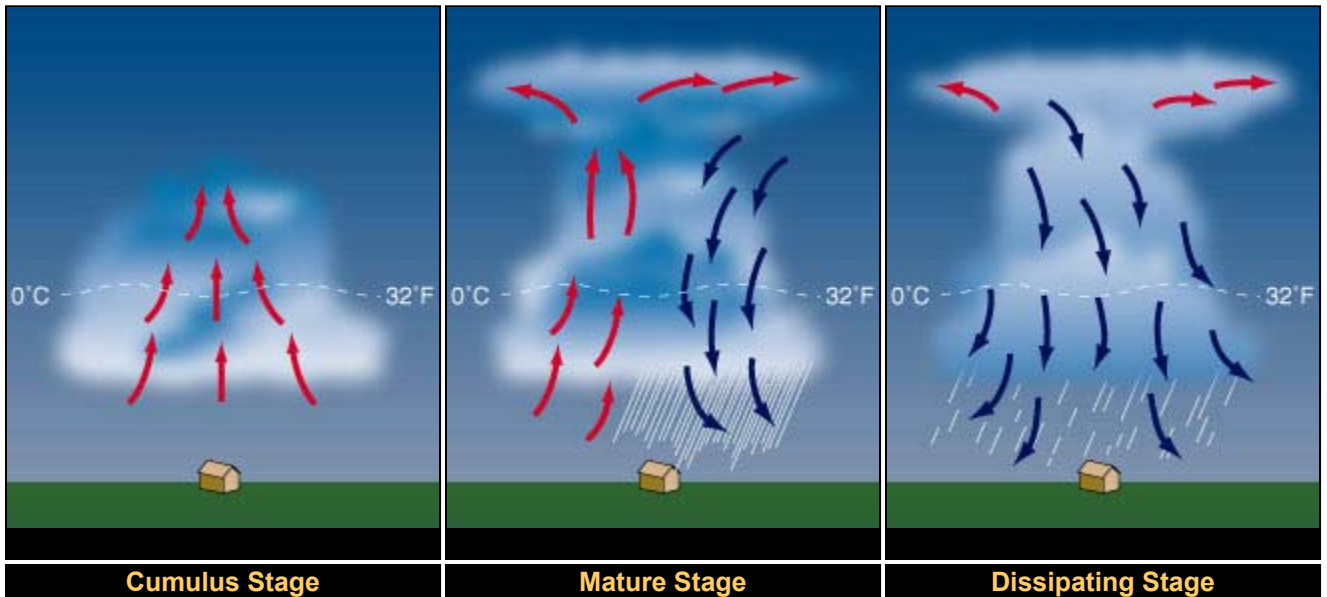

Know the Facts

- All thunderstorms produce lightning and they are very dangerous.
- Lightning is hotter than the surface of the sun! On average, lightning is 54,000°F.
- A lightning flash is no more than one inch wide.
- The reason we see lightning before we hear thunder is because light travels faster than sound!

Experiment 1: "Mouth Lightning"**Lightning****MATERIALS:**

"Wint-O- Green" or "Pep-O-Mint" lifesaver

a dark room

Mirror

**PROCEDURE:**

1. Enter a really dark room and wait a few moments until your eyes get accustomed to the darkness.
2. Then pop a "Wint-O- Green" or "Pep-O-Mint" lifesaver into your mouth.
3. While keeping your mouth open, break up the lifesaver with your teeth and look for sparks. (use the mirror)

If you do it right, you should see little bluish flashes of light.

EXPLANATION: _____

Experiment 2: Make a Thunder**MATERIALS:**

1 - brown paper lunch bag

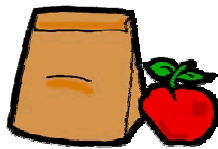
**PROCEDURE:**

1. Fill the brown paper lunch bag by blowing into it
2. Twist the open end and close with your hand
3. Quickly hit the bag with your free hand



EXPLANATION: _____

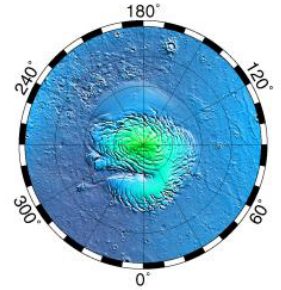
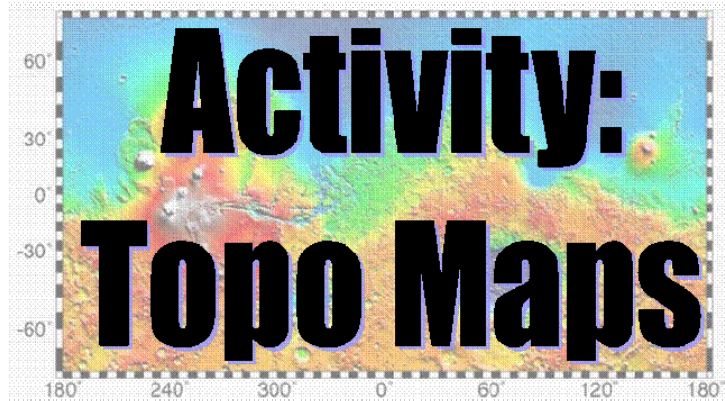
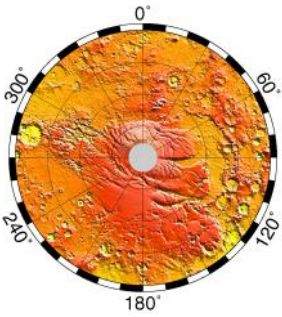

What is a Topographic Map?

A topographic map or "topo map," is a way to show different elevation of the surface like mountains, hills and valleys on a piece of paper. Topo maps are handy and necessary for many uses, including building roads and hiking trails in the mountains. The map shows where the hills and valley are and how steep they are. (Slope: be at an angle; "The terrain sloped down)

What Do "Topo" Maps Show us?

A topographic map shows us the distinctive characteristic of the Earth's surface using contour lines. **Contours** are imaginary lines that join points of equal elevation on the surface of the land or sea level. Contours make it possible to measure the height of mountains, depths of the ocean bottom, and

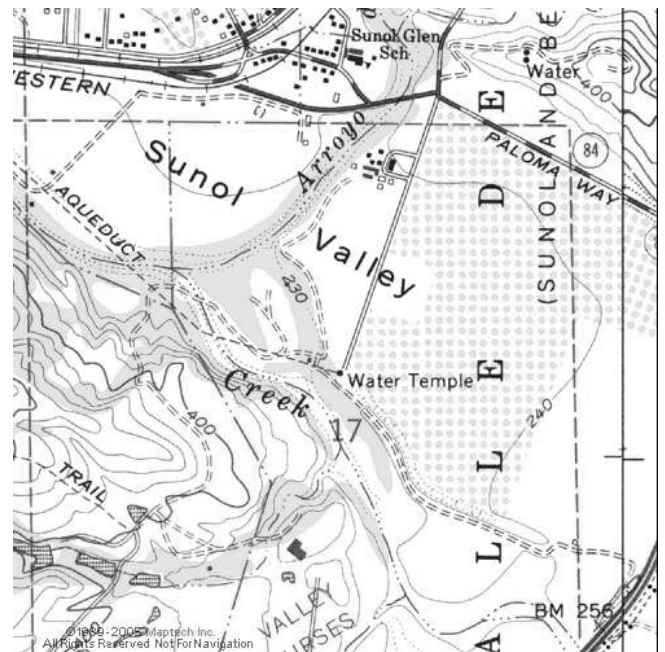

steepness of slopes.

Beside that "Topo" map shows more than contours. The map includes symbols that represent such features as streets, buildings, streams, and vegetation. These symbols are constantly refined to better relate the features they represent, improve the appearance or readability of the map, or reduce production cost.

What technology is available to get accurate readings and designs the maps?

We can use a technology called **imaging radar** to help create a picture of the terrain on Earth. Imaging radar instruments are flown over the land (or water) in airplane.

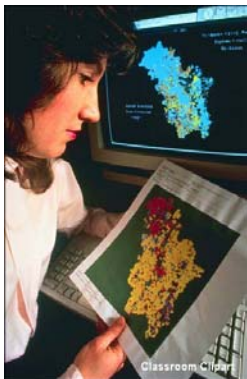

Let's Build a Topo Map

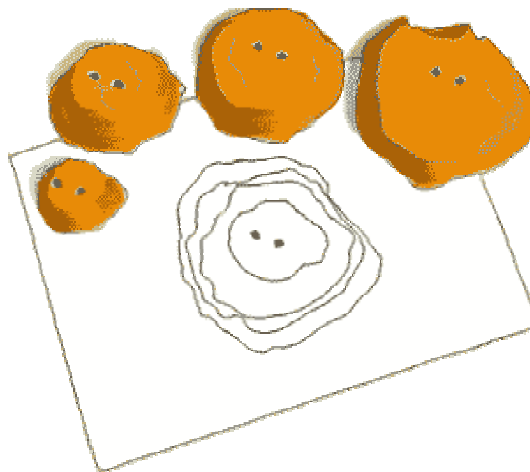

Materials:

- A lump of clay or Play-Doh® about the size of a coffee mug.
- Piece of cardboard or large tile on which to work the clay
- Piece of dental floss, about 2 feet (around 60 centimeters) long
- Ruler
- Piece of plain, white paper
- Long pencil
- 2 toothpicks
- Crayons

Step by Step Directions:

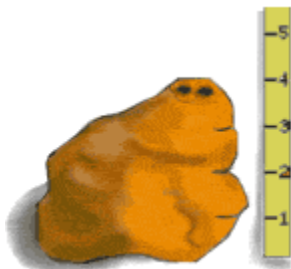

1. Put the lump of clay on the cardboard and shape a mountain about 4 inches high. Making the map is more fun if you make your mountain a little lopsided or oddly shaped. However, the mountain should be flat on the bottom.

2. Use the long pencil to poke two holes straight down through the center of the mountain. Make sure your two holes go all the way through the mountain.

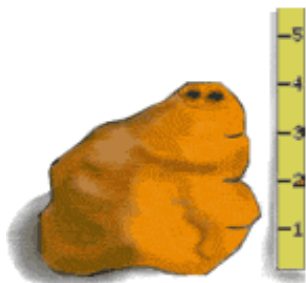
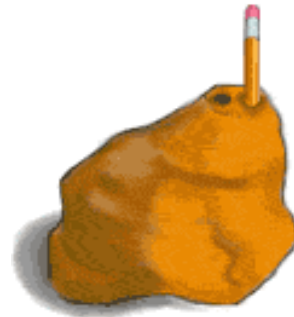

3. With the ruler, measure down about 1 inch (2.5 centimeters) from the top of the mountain and make a little dent mark with the pencil. Make two more dent marks lower down on the mountain about 1 inch apart. Or, without using the ruler, just make three marks to divide your mountain into four slices all about the same thickness.



4. Stretch the dental floss until it is taut, wrapping the ends around your fingers so you have a good grip on it. Use the dental floss to cut through the mountain at top-most mark you made. Hold the floss as horizontal (level with the table or floor) as you can.

5. Remove this clay slice and place it on the paper. Use the pencil to carefully trace around it. Push the pencil through one of the holes in the clay and make a dot on the paper; do the same with the other hole. Put the slice aside, but don't squash it. You'll need it again later.

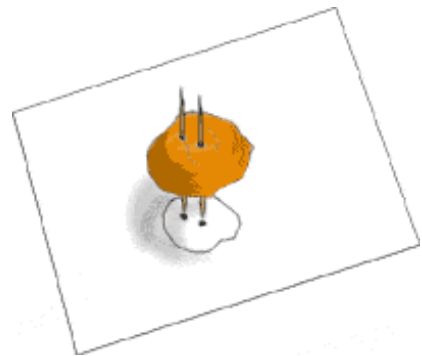

6. Cut a second slice at your next mark down from the top. Lay the second slice over the tracing of the first one, being careful to place the holes in the second slice over the dots on the paper. To line up the holes, poke the two toothpicks through the holes in the slice and line them up with the two dots on the paper. Carefully trace around the second slice. Your tracing will form

a circle outside the tracing of the first slice. (If you have "outcroppings" on your mountain, the second circle could cross into the area of the first circle).

7. Cut another slice at the next mark down. Line up the holes with the dots and trace it as you did before. Finally, place the bottom slice on the paper, line up the holes, and trace it.



8. Stack the slices back up in order on the cardboard. Be sure the holes line up.

9. Admire your topo map!

10. Compare the topographic map you have just made to the model mountain.

11. Finally, let's create a legend for our topo map, since we make the mountain's cut based on height, our legend will be describing the possible height of each area in the topo map. For example;

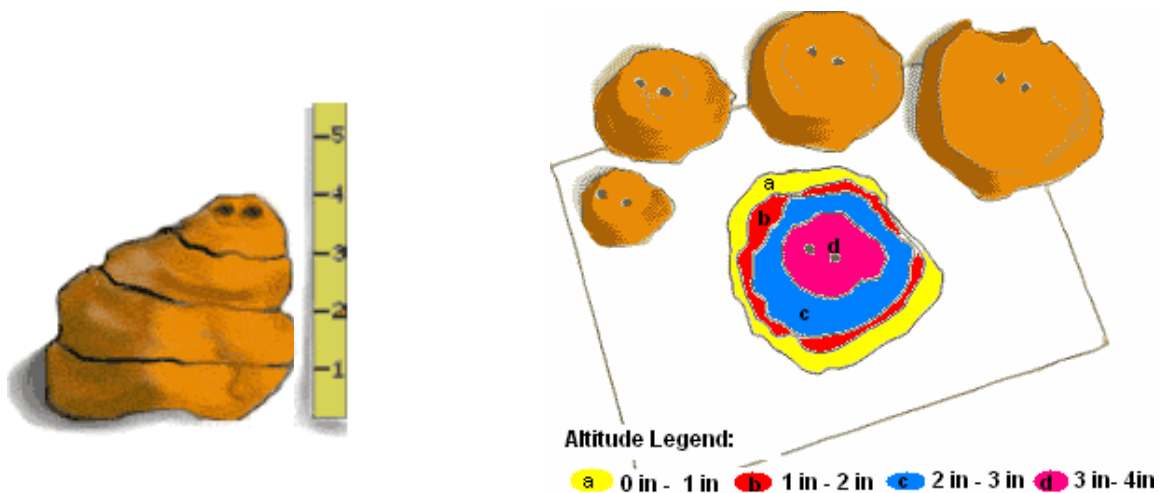

Conclusions:

1. Why are some of the traced lines closer together than others? _____

2. On your topographic map, where are the steepest slopes? _____

3. Looking at your map, where would be the best place to build a trail to climb to the top of the mountain? _____

4. Do you think the topo maps are useful? If yes, why? _____

References:

<http://www.enchantedlearning.com/geography/mapreading/topo/>

<http://spaceplace.nasa.gov>



"Topo" Maps Understanding Activity



Topographic Map (with contour lines that show points that are on the same level)

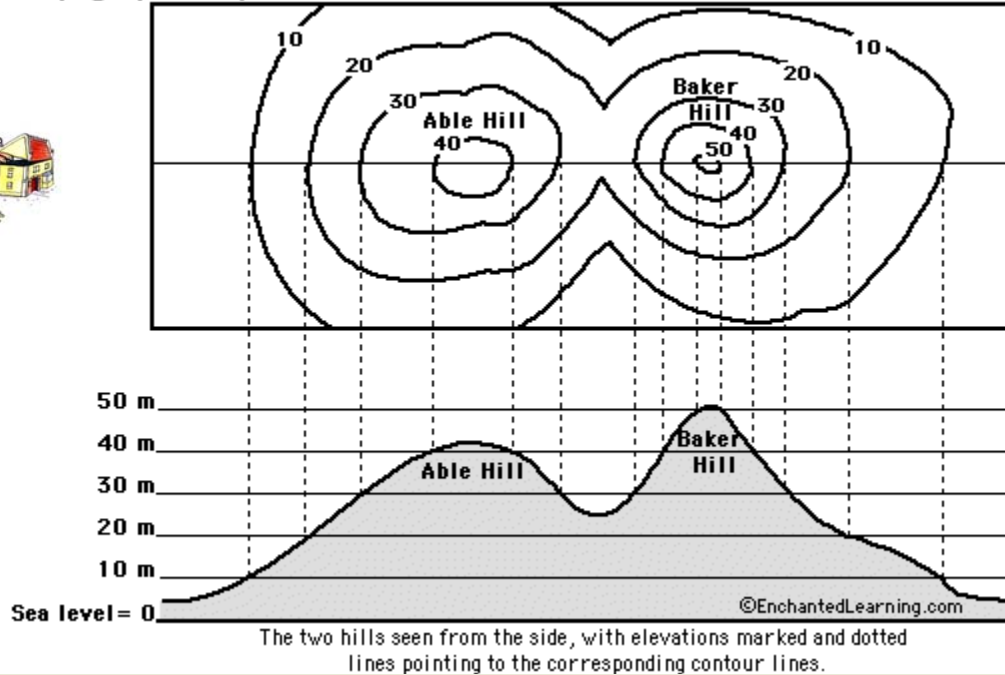

Color the elevations on the topographic map as follows. Red: 50m and higher, Orange: 40-50m, Yellow: 30-40m, Light green: 20-30m, Dark green: 10-20m, Purple: 0-10m.

Answer the following questions using topographic map shown above.

1. Approximately how tall is Able Hill? _____

2. Approximately how tall is Baker Hill? _____

3. Which mountain is taller, and by about how much? _____

4. How many meters of elevation are there between contour lines on the topographic map? _____

5. Which mountain has steeper slopes? _____

6. Are the contour lines closer together on Able Hill or Baker Hill? _____

Simulators

What is a model?

Physical Representation

What is Simulation?

- **Simulation** is the process of designing a **model** of a **real system** and **conducting experiments with this model** for the purpose of either understanding the behavior of the system and/or evaluating various strategies for the operation of the system.

Simulators Links



Earthquake

<http://tlc.discovery.com/convergence/quakes/interactives/makeaquake.html>



Tsunami

<http://chair.pa.msu.edu/applets/tsunami/tsunami.html>



Hurricane

<http://meted.ucar.edu/hurricane/movncane/movncane.htm>



Tornado Simulator

<http://whyfiles.org/interactives/tornado.html>



Volcano Simulator

<http://volcano.und.nodak.edu/vwdocs/kids/fun/volcano/volcano.html>

What is a tornado?

A tornado is a violent rotating column of air extending from a thunderstorm to the ground.

Activity #1:

Map Showing Tornado Risk Areas in the Conterminous United States

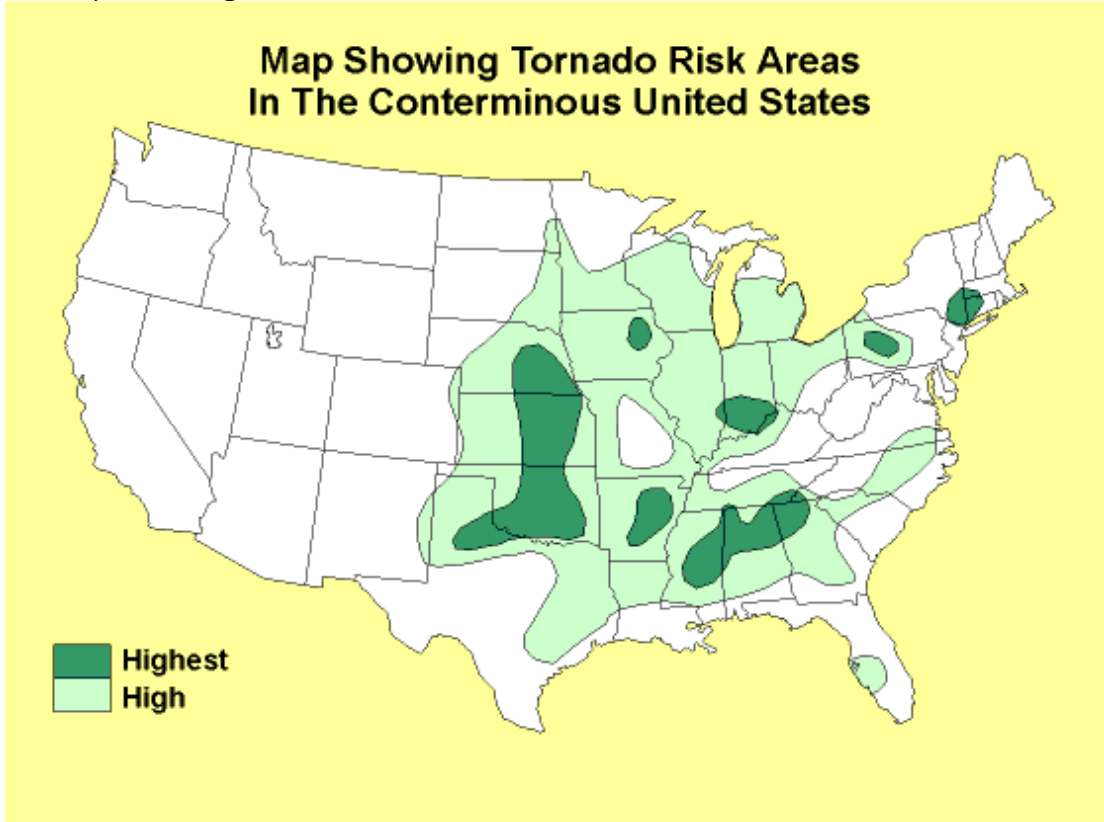

A. List 5 states that have the highest tornado risk

1. _____
2. _____
3. _____
4. _____
5. _____

B. List 5 states that have high tornado risk

1. _____
2. _____
3. _____
4. _____
5. _____

References: <http://www.usgs.gov/themes/map6.html>

Rapid Land Changes

Use the word bank below to fill in the blanks.

flood earthquake volcano

The Earth's surface can change over millions of years or within minutes. Let's look into the rapid changes that can happen to the land.

Earth's crust is made up of many pieces that fit together like a jigsaw puzzle. These pieces push each other, slide past each other, and even pull away from each other. When these movements happen they cause _____. An _____ is the shaking of the Earth's surface caused by movement in the crust and mantle.



A _____ is an opening in the Earth's surface from which lava flows. Lava and ash build up around the opening to form a mountain. The lava flows down the mountainside to form new land as it cools.

Sometimes water can change the Earth's surface very quickly. During heavy rains and if rivers cannot hold all the water, they overflow their banks and cause a _____. A _____ is a large amount of water over normally dry land. As the water comes it leaves soil and sand behind.



Processes that shape the Earth

What did you learn?

How does a volcano create a rapid land change?

What is a contour line?

How is lightning formed?

What is a simulation?

How does sunlight and heat affect glaciers?

What technology allows map makers to get more accurate readings for designing maps?



Read all about it!!!
Force and Motion
is next!



Force & Motion

What do you know?

Part I. Fill the blanks

free body diagram

force

density

scalar

point of reference

save

gravity

aqueduct

- Speed is a _____ because it has a magnitude but no direction.
- A _____ has magnitude and direction.
- Gravity is a natural _____ that tends to draw objects towards the center of Earth and other celestial bodies.
- A _____ is a diagram that shows all the forces acting on an object.
- An astronaut can float in space because there is very little _____.
- A _____ is a conduit or channel intended to moves water from the source like a lake or river to the city.

Part II. Choose the Best Answer

- What is the amount of the force of gravity on earth?
 - -20 m/s^2
 - -5 m/s^2
 - -9.8 m/s^2
- _____ is the energy possessed by an object due to its motion.
 - Potential Energy
 - Kinetic Energy
 - Synthetic Energy

Part IV. Short Answer

9. Why is the gravity on earth a negative quantity?

10. What is force? Give an example of a non-contact force?

11. What is pressure?

12. What is the difference between force and pressure?

13. What is work? (Hint: it is not the place where your parents go everyday!!)

14. How can the sun produce work?



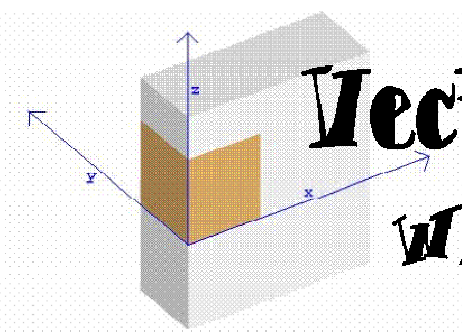

Vectors & Scalars

What's the difference?

Let's start with a few definitions...

- Some physical properties, such as temperature or area, are given completely by their magnitude and so only need a number. These quantities are called **scalar** values.

Sample questions for which the answer is a scalar:

- At sea level, water boils at the following temperature °C.
- Find the area in m^2 of a rectangle 3 m in width and 5 meters in length.

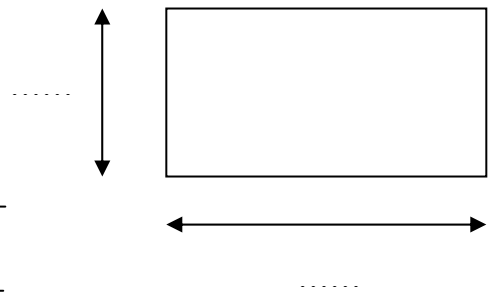

- There are other physical quantities, such as weight, velocity and acceleration, for which we must know direction as well as size or magnitude in

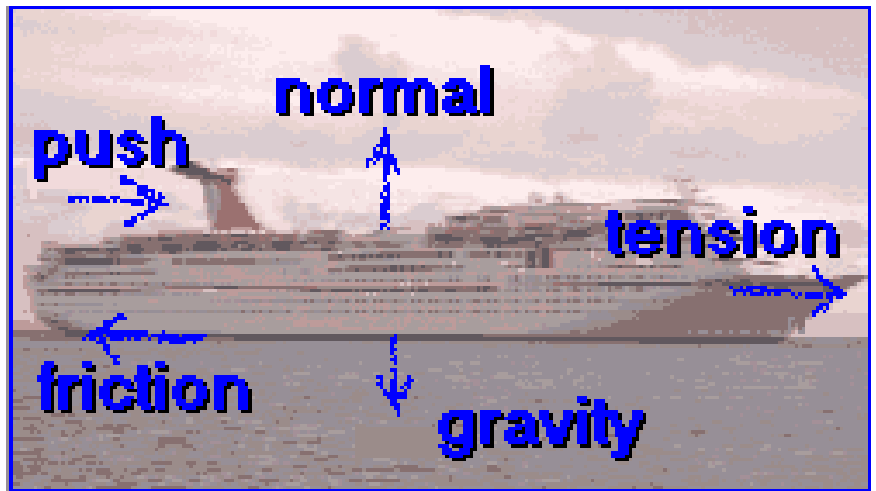

order to define them. It is often very helpful to represent such quantities by directed lines called **vectors**.

There is a method called **free body diagram**, which is often used by physicists problems to show all the mechanical or electromagnetic forces (represented by **vectors**) acting on the given **free body** (or bodies) at any given time. Doing so can make it easier to understand the **forces**, and **moments**, in relation to one another and suggest to the physicist the proper **approach** to apply in order to solve the problem.

Let's see an example where we have two kinds of **simple machines** available.

Can you name the simple machines in the diagram below.

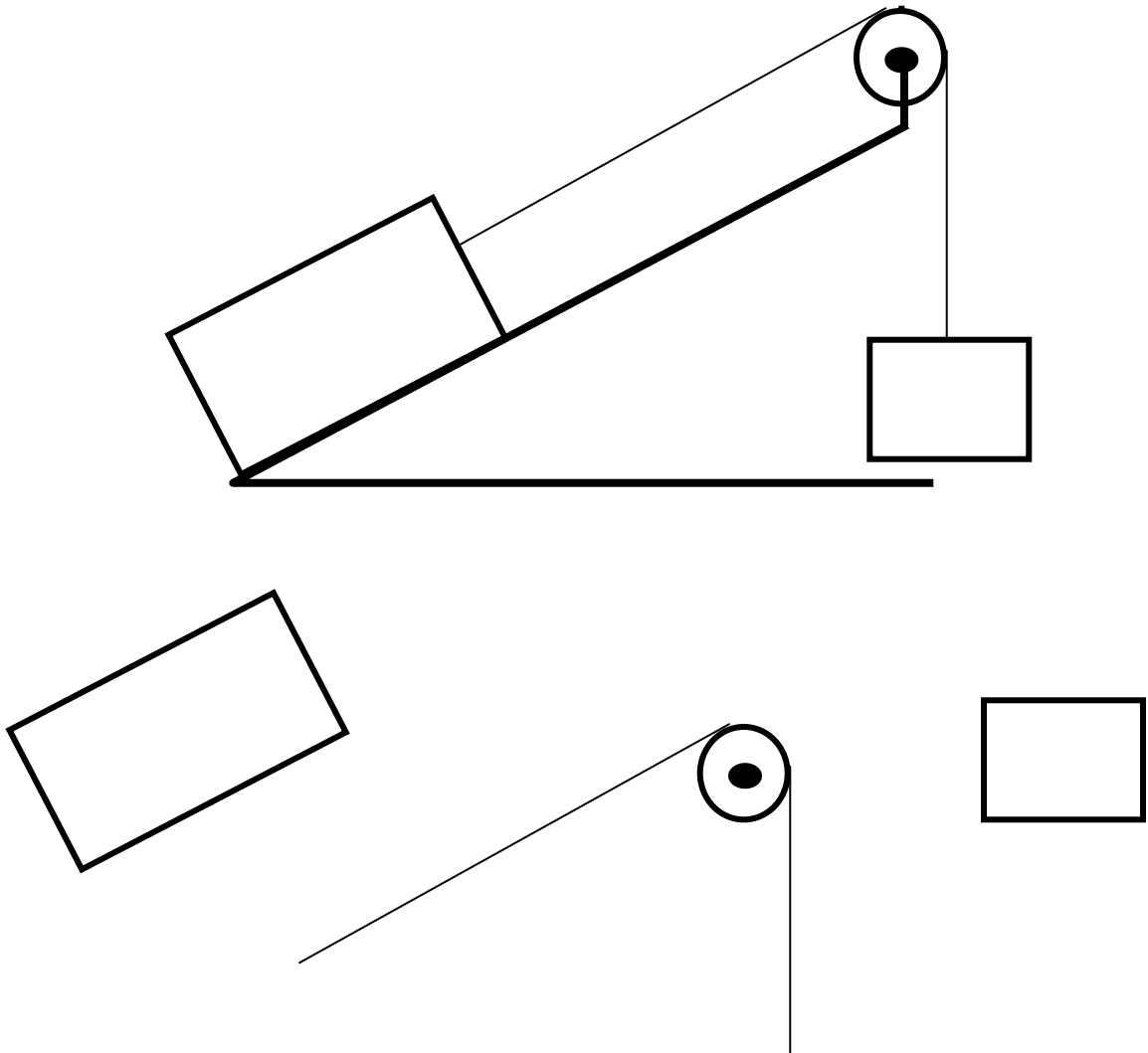

Name _____

Date _____

Lesson Notes

Contact Forces

Frictional Force

Tensional Force

Normal Force

Air Resistance Force

Applied Force

Spring Force

Action-at-a-Distance Forces

Gravitational Force

Electrical Force

Magnetic Force

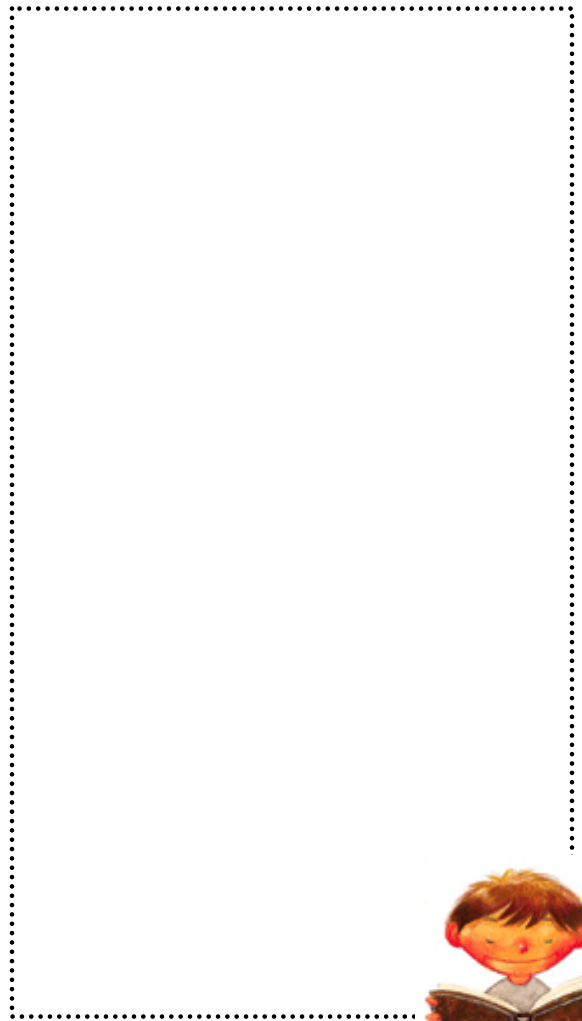

Here are some more examples of problems that need free body diagrams to help solve for the forces involved:

A diagram of a pulley system. A block labeled 'A' with a mass of '5 kg' is on a horizontal surface. A rope is attached to the block, passes over a pulley, and then hangs down to a second block labeled 'B' with a mass of '2 kg'. A dashed rectangular box to the right of the pulley system is labeled 'Free body diagram' at the top.

A diagram of a block on an inclined plane. The block is on a ramp that slopes upwards from left to right. A dashed rectangular box to the right of the ramp is labeled 'Free body diagram' at the top.

Here is a tough one... Try to find which direction the 10 kg box is moving. How about the 200 kg slab?

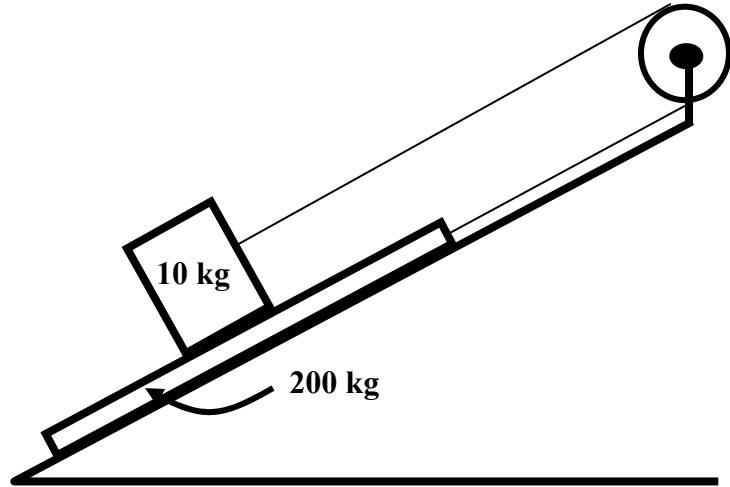

Free body diagram



Appendix

Simple machines- transfer of force and energy

At a basic level, machines transfer force from one direction to another, or change the magnitude of force required to do something. The six "simple machines" are

Plane	Wheel
Wedge	Pulley
Screw	Lever

The first three are closely related- they all take a force and point it in a new direction at a right angle to the original force.

Plane

Imagine trying to lift a box that is 100 kg straight up to a height of one meter- it would be really difficult! If you slide that same box up a ramp, however, you would be able to do it. It might take you longer to slide it all the way to the top, but at each stage you don't have to pull as hard.

Wedge

If you want to separate two things that are very close together, you can use a wedge. If there were two heavy blocks side by side with only a tiny gap between them, you could place a wedge in the gap, then push down on the wedge. The force pushing down would push sideways against the two blocks and make them separate.

Screw

A screw converts rotating motion to linear motion. A screw is basically an inclined plane wrapped in around an axis. You can see this by taking a triangle and wrapping it around a pencil- it looks like a screw.

Wheel

Wheels do to things: reduce the force of friction (since the point of friction is moving opposite the direction of motion, the friction force is made much smaller), and change torque ratios. If you have a wheel with an axle as shown, trying to turn the axle will make the wheel turn as well, and makes it turn by a large distance (as measured on the edge of the wheel), but it is difficult to do so. Turning the wheel

will make the axle turn, and can do so easily, but the axle turns by only a small amount.

Pulley

A pulley can change the direction a force is being applied in. Using multiple pulleys can reduce the force required to lift an object, but you must pull the rope further in order to lift it the same distance.

Lever

Levers can change the direction of force, change the proportion of force (and naturally distance as well), or both, depending on their arrangement.

- A class one lever has its fulcrum located somewhere between the effort and the load. Examples of class one levers are seesaws, scissors, and pliers.
- A class two lever has the fulcrum at one end, the effort at the other end, and the load in the middle. Examples are wheelbarrows, screwdrivers, nutcrackers, and staplers.
- A class three lever has the fulcrum at one end, and the effort is between the fulcrum and the load. Examples are baseball bats, hockey sticks, fishing poles, and golf clubs



Water Force & Pressure

Pre-lab Activity

Think about the following questions and be prepared to discuss them with you teacher:

1. Circle the answer (s) that describe force the best
 - (a) A force is a push or a pull
 - (b) A force is composed of an intensity and direction
 - (c) Both (a) and (b)

2. List 4 different forces that you encounter everyday

1) _____ 2) _____ 3) _____ 4) _____

3. Circle the answer (s) that describes best pressure
 - a) Pressure is how hard you push on a specific area
 - b) Pressure is force divided by area
 - c) Both (a) and (b)



Name _____

Date _____

Lesson Notes

Lined area for writing notes on the left side of the page.

Dotted-line area for writing notes on the right side of the page.

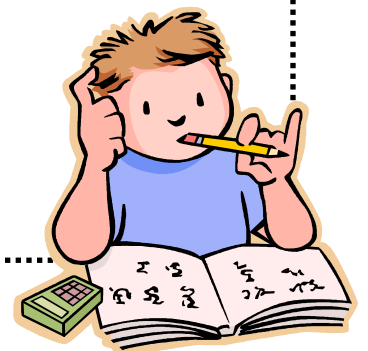

Lab activity

Materials:

- Masking tape
- 2 x 2 bottles of soda, Gatorade, water
- shallow basin to collect water
- lab worksheet



Activities:

Cover the holes that are found on the side of the bottles then fill the up with water while. Make sure you cap the bottles.

1. Hypothesize what you think will happen when the tape is removed without taking the cap of.

2. What happens when you take the cap off from the first bottle (as shown in the schematics)? Sketch the streams in the schematic.

3. What happens when you take the cap off from the second bottle (as shown in the schematics)? Sketch the streams in the schematic.

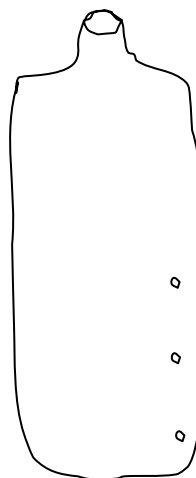
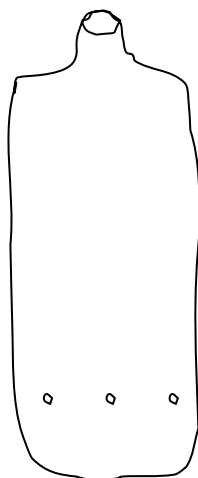

Questions:

1. Which hole has the strongest stream? Why?

2. Which hole has the weakest stream? Why?

3. Why isn't there any difference in the stream between the holes in the second bottle?

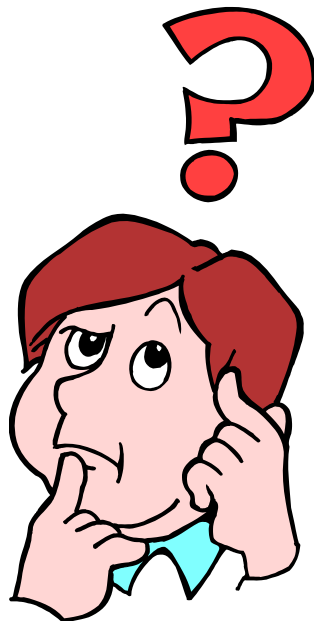

Post Lab Activity

Pasta-paper composite bridge

This hands-on-activity helps students learn about the importance of composite material use in optimizing mechanical stability of a structure better than the individual materials used.

PROCEDURE:

- 1) Cut a sheet a paper in 5 equal parts as shown in figure. These sheets will be stacked on top of each other with pasta between each two layers.
- 2) Take the provided "spaghetti" pasta and cut 40 equal pieces that are $8\frac{1}{2}$ " in length each.
- 3) Use Elmer's glue to glue a maximum of 10 pieces each two layers.

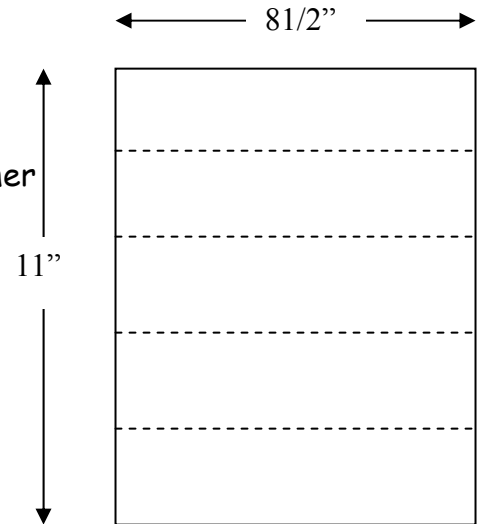

COMPETITION:

The final product will be twisted 90 degrees then bent in such a way that the distance between the long edges equals 6". Then the bridge will be put on between two edges with a free span equal to $7\frac{1}{2}$ ". Weights will be added until the bridge falls or breaks.

The winning bridge is the one that carries the largest weight without falling or breaking.

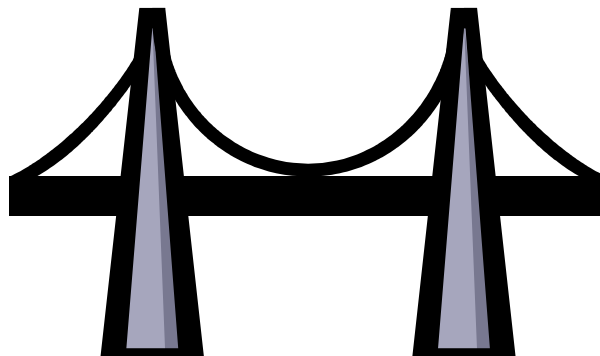

Shooting the cannon: A Simulation

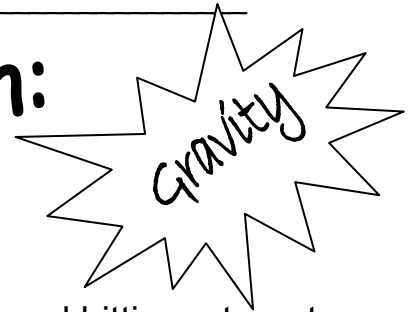

In this simulation activity you will be shooting a cannon and hitting a target. You will be changing some of the variables of the simulation to see if your results change.

DIRECTIONS

TRIAL 1

1. Click on the SHOOT button. Notice what it does.
2. Click on the MORE button. Notice what it does.
3. Set up the variables like this:

Angle is 60	Velocity is 16	Gravity is -9.8
Windage is 0	Density is 1.1	Drag is NOT checked

4. Record the velocity in the FIRE 1 velocity space.
5. Click SHOOT. Record the distance in the FIRE 1 distance space.
6. Record Y if you hit the target or N if you did not in the FIRE 1 Y/N space.
7. Change only the VELOCITY to try to hit the target. Each time, write the velocity you entered and the distance the shot fired. Also, don't forget to circle Y or N if you did or did not hit the target. Do this for FIRE 2, FIRE 3, FIRE 4, and so on until you get a hit.

	Velocity	Distance	Hit
FIRE 1			Y / N
FIRE 2			Y / N
FIRE 3			Y / N
FIRE 4			Y / N
FIRE 5			Y / N
FIRE 6			Y / N

TRIAL 2

8. Now, let's change something. Set up the variables like this:

Angle is 60	Velocity is 16	Gravity is -14
Windage is 0	Density is 1.1	Drag is NOT checked

9. What did we change from the first trial?

10. Record the velocity in the FIRE 1 velocity space.

11. Click SHOOT. Record the distance in the FIRE 1 distance space.

12. Record Y if you hit the target or N if you did not in the FIRE 1 Y/N space.

13. Change only the VELOCITY to try to hit the target. Each time, write the velocity you entered and the distance the shot fired. Also, don't forget to circle Y or N if you did or did not hit the target. Do this for FIRE 2, FIRE 3, FIRE 4, and so on until you get a hit.

TRIAL 3

	Velocity	Distance	Hit
FIRE 1			Y / N
FIRE 2			Y / N
FIRE 3			Y / N
FIRE 4			Y / N
FIRE 5			Y / N
FIRE 6			Y / N

Now, let's change something. Set up the variables like this:

Angle is 60	Velocity is 16	Gravity is -20
Windage is 0	Density is 1.1	Drag is NOT checked

14. What did we change from the second trial?

15. Record the velocity in the FIRE 1 velocity space.

16. Click SHOOT. Record the distance in the FIRE 1 distance space.

17. Record Y if you hit the target or N if you did not in the FIRE 1 Y/N space.

18. Change only the VELOCITY to try to hit the target. Each time, write the velocity you entered and the distance the shot fired. Also, don't forget to circle Y or N if you did or did not hit the target. Do this for FIRE 2, FIRE 3, FIRE 4, and so on until you get a hit.

Name _____

Date _____

Now let's graph our HITS!

In the space below graph the gravity vs velocity of the HITS in the three trials. Don't forget the title.

	Velocity	Distance	Hit
FIRE 1			Y / N
FIRE 2			Y / N
FIRE 3			Y / N
FIRE 4			Y / N
FIRE 5			Y / N
FIRE 6			Y / N

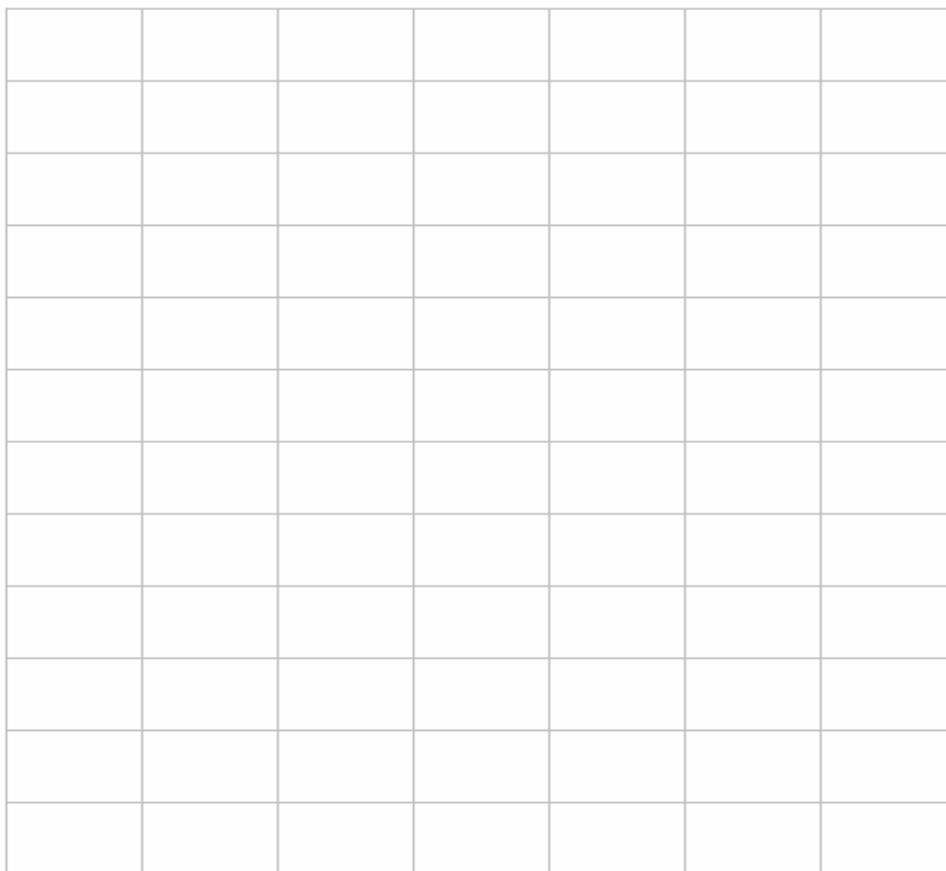

20. Extend the line that was drawn in the Gravity vs Velocity graph. Use the graph to estimate what velocity is needed when the gravity is -2.0 . Write the velocity that you think is needed to hit the target in the space provided _____.

21. Set the velocity to hit the target. Click the Fire button. Continue to change the velocity until the target is hit.

22. Use the graph to estimate what velocity is needed when the gravity is -13.0 . Write the velocity that you think is needed to hit the target in the space provided _____.

23. Set the velocity to hit the target. Click the Fire button. Continue to change the velocity until the target is hit.

Some Questions

1. What variables did we change?
2. What variables remained the same?
3. What did you notice that gravity did to the velocity of the ball that the cannon fired?
4. What did you find interesting about this simulation?

Engineering

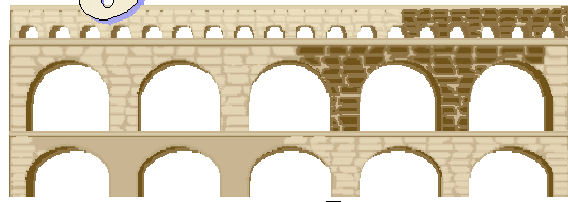

Aqueducts

Introduction:

An aqueduct is a *conduit* or a channel intended to transport water from source to the city. The water came either from a stream whose waters collected in a pool to which the aqueduct was connected, or directly from a river using a dam. On arrival at a high point in the city, the water from the aqueduct went into a vast reservoir (water tower) from which several large pipes led. These pipes then branched out to supply the different districts. During a time length of over 500 years, eleven main aqueducts, plus a considerable number of branches, were built for Rome's urban needs. It has been assessed that, all together, the total output of these aqueducts was considerably more than the daily amount of water the modern city can rely upon today.

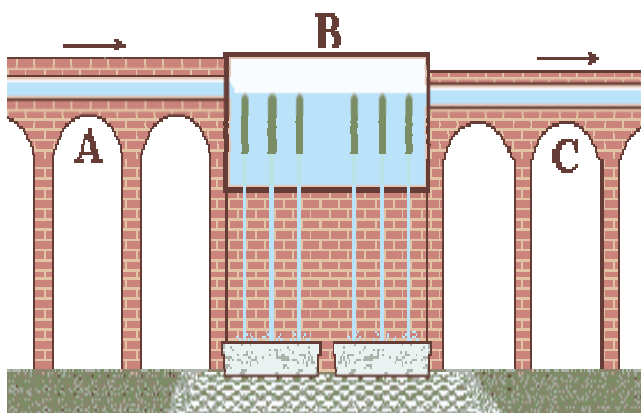

Figure 1: (a) an example of a roman aqueduct architecture. (b) series of arches of the *Aqua Alexandrina*, the last aqueduct built in ancient Rome, in AD 226. adapted from http://f_pollett.tripod.com/roma-aq1.htm

Pre-lab Activity



1) What do you think the word aqueduct means?

2) What was the main purpose of these aqueducts?

3) What force was exploited to move the water for the source to the city?

4) Explain the reason behind using the arches in the architecture of the aqueducts.



Now let's explore the science behind aqueduct structures and draw one. You will need a compass, a ruler, a square, and a protractor.

Name _____

Date _____

Lesson Notes

Lined area for writing notes, consisting of 25 horizontal lines.

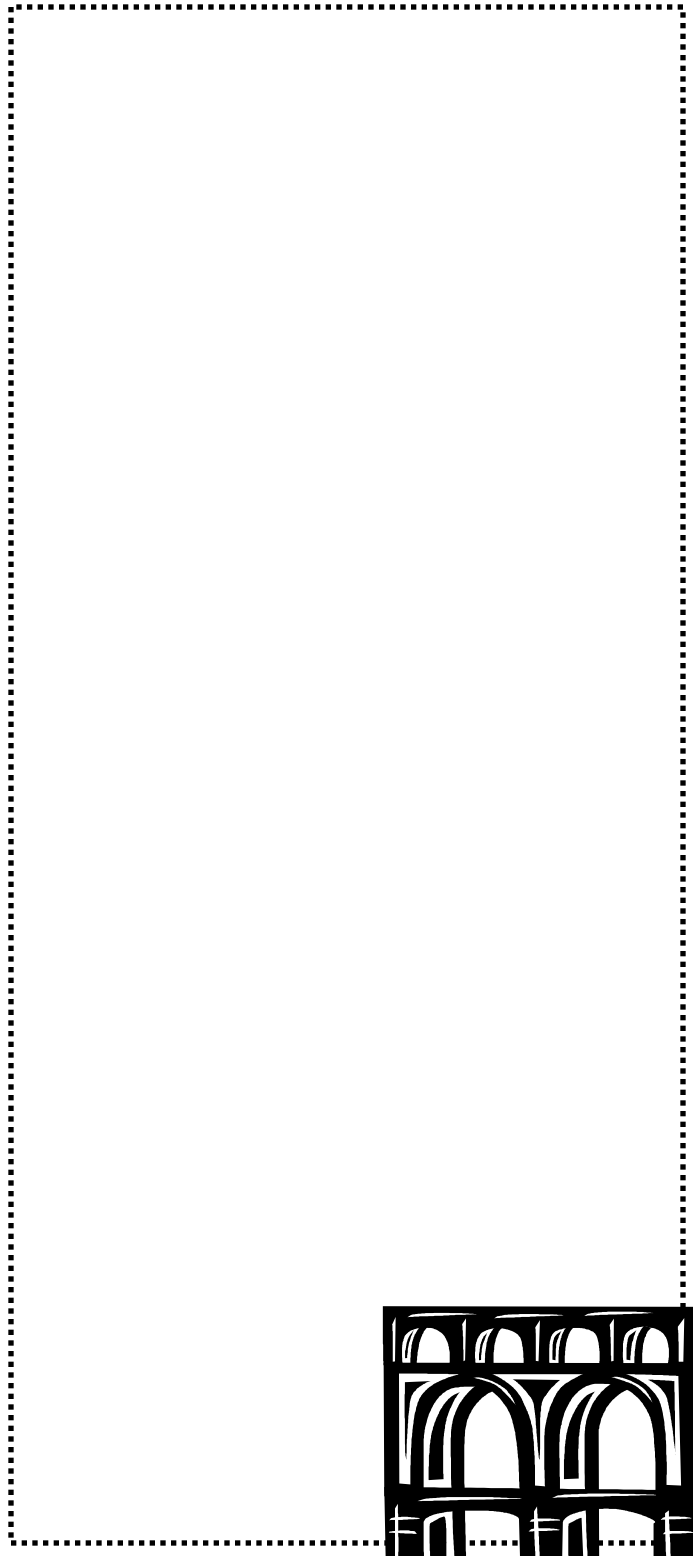

Name _____

Date _____

"Engineering Blue Prints" for Ancient Roman Aqueducts

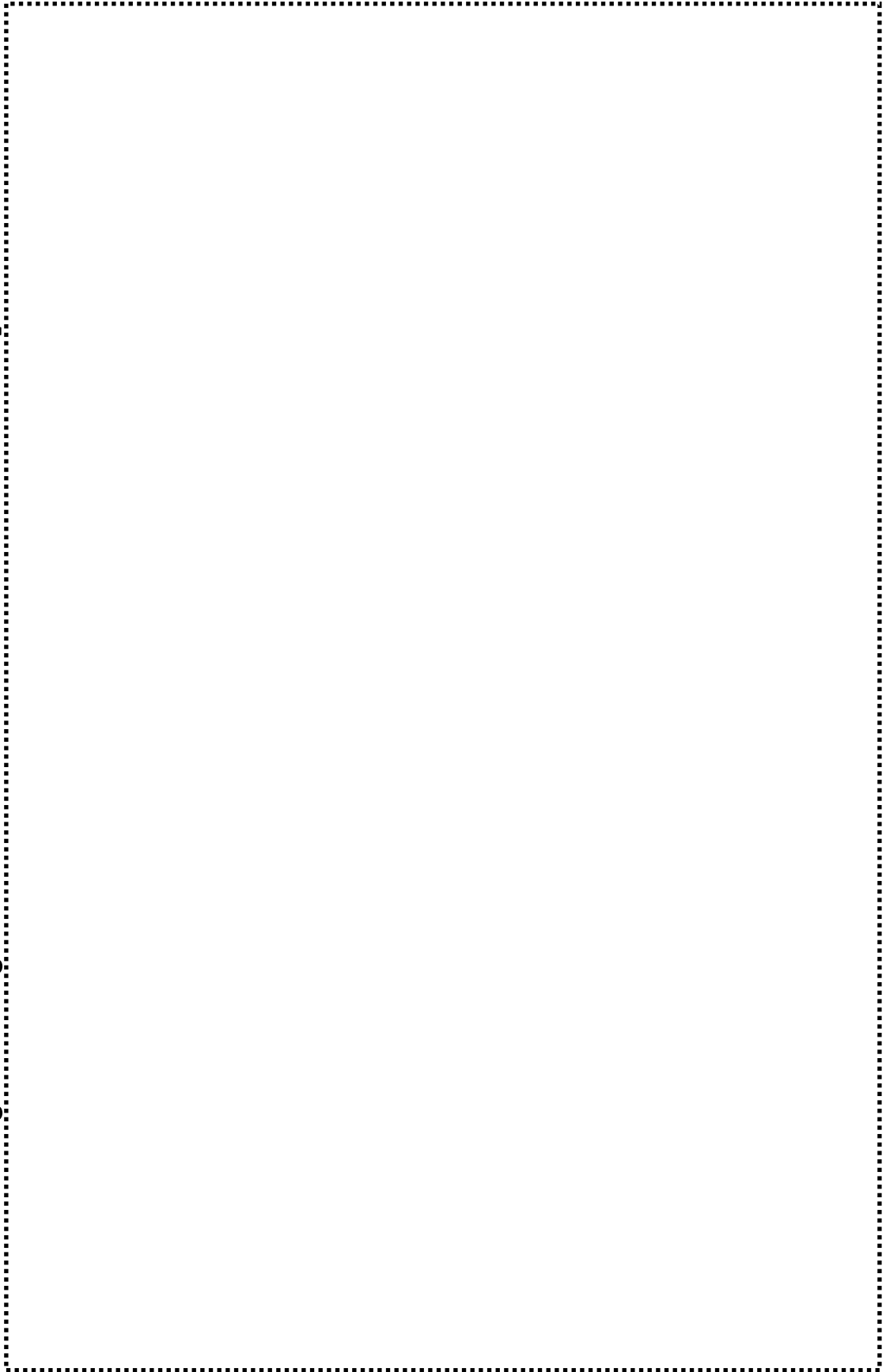

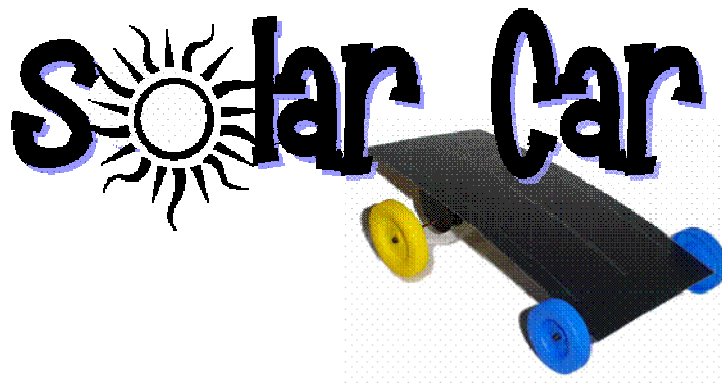

Experiment objectives

Today's experiments will explore the use of light as a source of energy to power a motor.

Question/Hypothesis

- 1) Think about how light could be turned into work.

Materials

- Light source
- Solar panels
- DC motor
- Nerf ball with counter

1. What is a force? Give an example of a non-contact force

2. What is pressure?

3. What is the difference between force and pressure?

4. Why do we need a free body diagram?

5. What is work? (Hint: it is not the place your parents go to everyday!)

6. How can we use the sun to produce work?

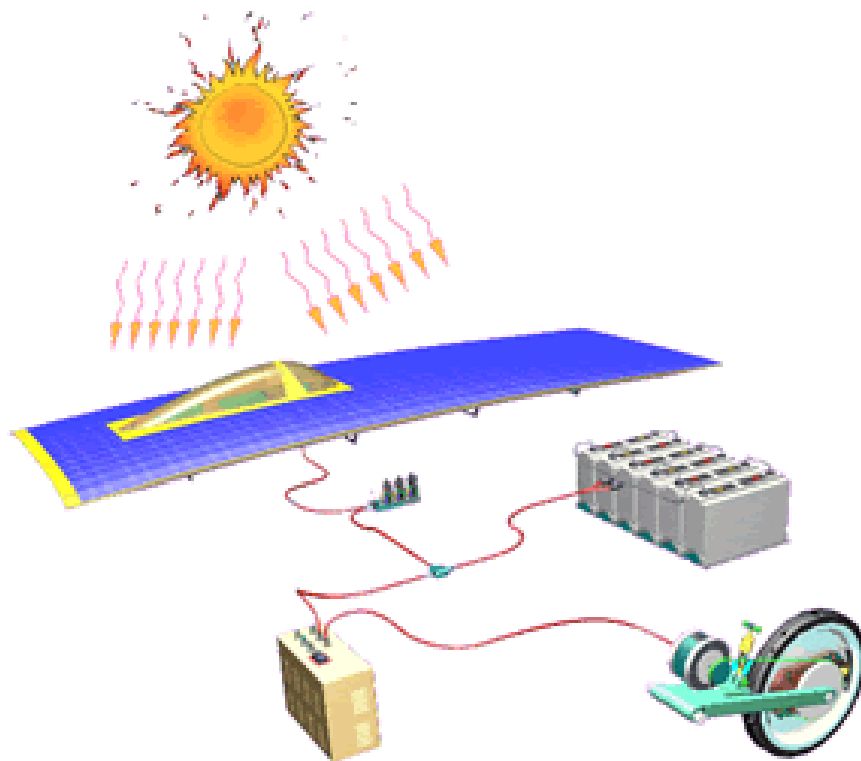

Name _____

Date _____

Lesson Notes

Lined area for writing notes, consisting of 25 horizontal lines.

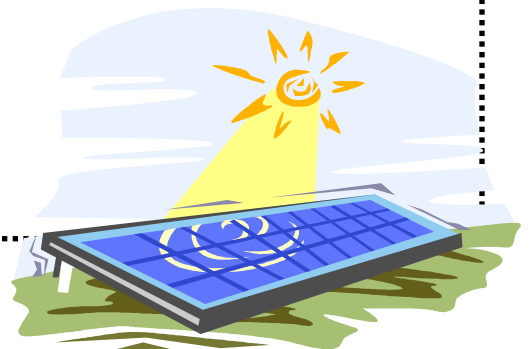
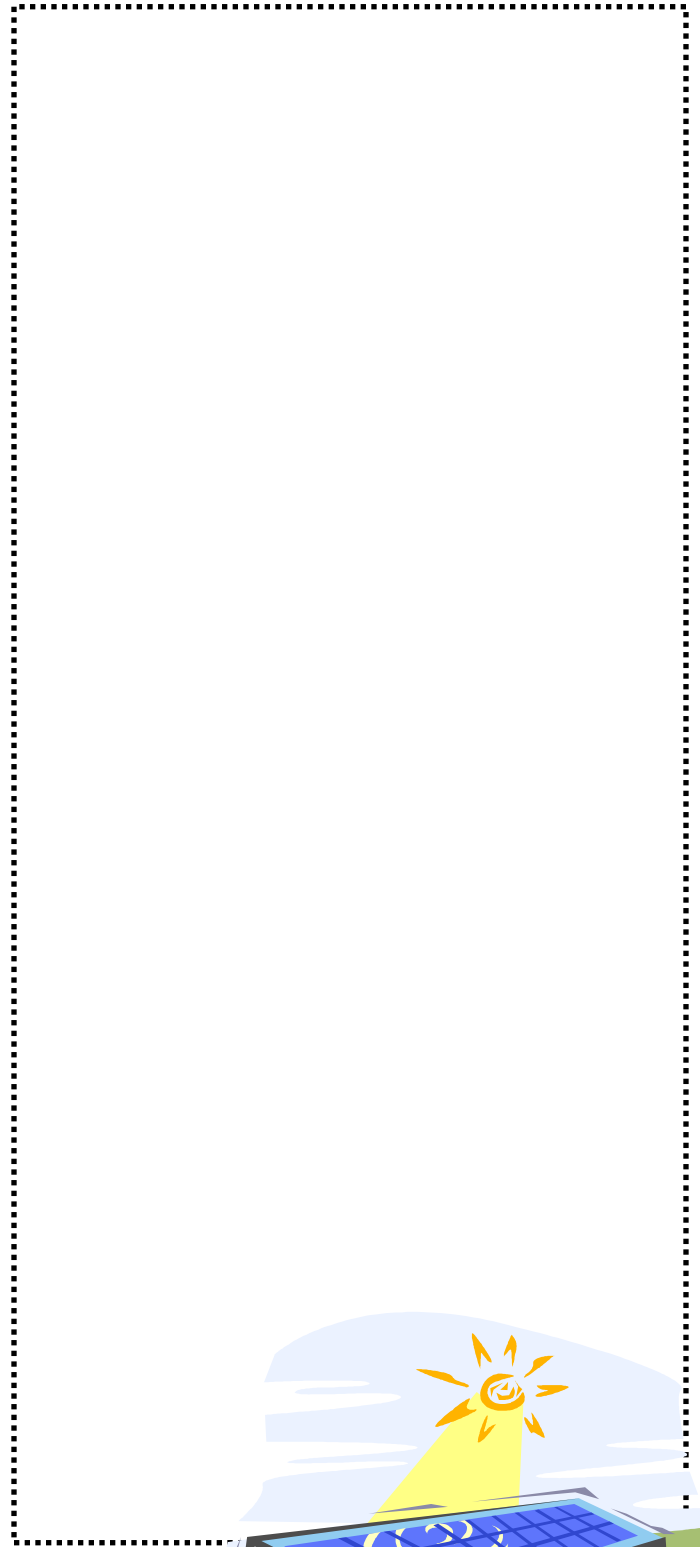

RESULTS:

Empty rectangular box for writing results.



Name _____

Date _____

GRAPH:

Name _____

Date _____

GRAPH:

CONCLUSION:

Force & Motion

What did you learn?

Part I. Fill the blanks

free body diagram	force	density
scalar	point of reference	
save	gravity	aqueduct

- Speed is a _____ because it has a magnitude but no direction.
- A _____ has magnitude and direction.
- Gravity is a natural _____ that tends to draw objects towards the center of Earth and other celestial bodies.
- A _____ is a diagram that shows all the forces acting on an object.
- An astronaut can float in space because there is very little _____.
- A _____ is a conduit or channel intended to moves water from the source like a lake or river to the city.

Part II. Choose the Best Answer

- What is the amount of the force of gravity on earth?
 d. -20 m/s^2 e. -5 m/s^2 f. -9.8 m/s^2
- _____ is the energy possessed by an object due to its motion.
 g. Potential Energy
 h. Kinetic Energy
 i. Synthetic Energy

Part IV. Short Answer

9. Why is the gravity on earth a negative quantity?

10. What is force? Give an example of a non-contact force?

11. What is pressure?

12. What is the difference between force and pressure?

13. What is work? (Hint: it is not the place where your parents go everyday!!)

14. How can the sun produce work?





Energy

What do you know?

<p>Is heat a form of energy?</p>	<p>What is the definition of conduction?</p>
<p>How can you measure heat?</p>	<p>What is the definition of radiation?</p>
<p>Can energy can be created? True or False</p>	<p>Energy can be destroyed? True or False</p>

ACTIVITY: Energy Regulators (Voltage and Current)

What is ENERGY???

Energy is defined as "The ability to do work." When we eat, our bodies transform the energy stored in the food into energy to do work. When we run or walk, we burn food energy in our bodies. When we think or read or write, we are also doing work. Energy can be found in a number of different forms.

Energy can be transformed into another sort of energy. But it cannot be created AND it cannot be destroyed. Energy has always existed in one form or another. A few of the many forms of energy include:

- chemical energy
- electrical energy
- heat (thermal energy)
- light (radiant energy)
- mechanical energy
- nuclear energy

Stored chemical energy in a flashlight's batteries becomes light energy when the flashlight is turned on. Food is also stored energy. It is stored as a chemical with potential energy. When your body uses that stored energy to do work, it becomes kinetic energy. If you overeat, the energy in food is not burned but is stored as potential energy in fat cells.

When you talk on the phone, your voice is transformed into electrical energy, which passes over wires (or is transmitted through the air). The phone on the other end changes the electrical energy into sound energy through the speaker. A car uses stored chemical energy in gasoline to move.

The engine changes the chemical energy into heat and kinetic energy to power the car.

A toaster changes electrical energy into heat and light energy (If you look into the toaster, you'll see the glowing wires). A television changes electrical energy into light and sound energy. Electricity is the flow of electrical power or charge. It is caused by the movement of electrons.

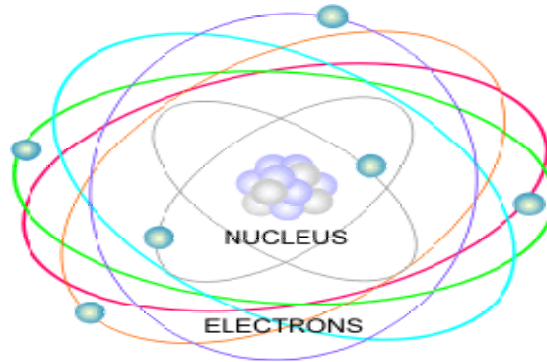

Making a Rheostat!

Background

A Rheostat is a device which allows you to control the speed of a fan. In order to accomplish this, the rheostat acts as a resistor. In other words, the rheostat stops the electrons in the circuit from reaching the fan or device. The rheostat is controlled by a knob that regulates the voltage in a circuit by increasing or decreasing the resistance in the circuit. For the given amount of the turn, the rheostat will use that much resistance.

Resistance, Voltage, and Current in a circuit are related by the formula:

$$V = IR$$

V=> Voltage

I=> Current

R=> Resistance

Objective

We will design a rheostat and observe the transfer of chemical energy (D cell battery) into electrical energy in the form of light. We will also define electrical resistance and examine how it affects the circuit.

Materials

- 1.) A flashlight bulb and socket
- 2.) Two "D" cell batteries or a dry cell lantern battery
- 3.) About 16 inches of wire
- 4.) A long spring (.5ft -1ft length)
- 5.) Pair of wire clippers

Procedure

- 1.) Connect the two batteries so the positive pole connects to the negative pole of the other battery.
- 2.) Cut the 16 inch wire in half and attach each piece to the open end of the joined batteries.
- 3.) Connect the free end of one wire to one terminal of the light socket
- 4.) Connect the other free wire to one end of the spring
- 5.) Connect the two-inch long wire to the other terminal of the light socket
- 6.) Connect the wire coming off the terminal to the end of the end where the other wire is. Watch how brightly the bulb glows (Figure 2).
- 7.) Now slowly move the short wire down the length of the spring.

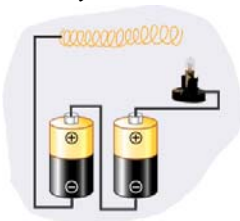

Figure 1: The bulb is not glowing.

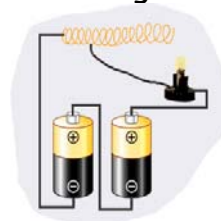

Figure 2: The bulb is glowing.

Conclusions

1.) What happens as you move further away from the end where the wire is attached to the spring? Why?

2.) What is the definition of Energy? What are the some of the different forms of energy?

3.) What type of energy transfer is taking place in this experiment?

4.) What is the voltage of your source?

5.) What is electrical resistance?

Harnessing the Wind

Mechanical Energy

Mechanical Energy is energy that can be transferred from one object to another to make something move, like wind blowing on a sail. Mechanical Energy can exist in two states: moving, or kinetic energy; and stored, or potential energy. A roller coaster is just one example of how mechanical energy is constantly changing form from potential to kinetic and back again.

Background

Wind speed is very important for wind energy. Wind turbines are the machines that change the movement of the wind into electricity. These turbines need a constant, average wind speed of about 14 miles per hour before the wind turbines can generate electricity. That's why wind farms, where there are a lot of wind turbines grouped together, they all are located in windy spots.

Objective

In this activity we will construct an anemometer which is a device that tells you how fast the wind is blowing. The device we will build is a model of a wind speed indicator. A real one will be able to accurately measure how fast the wind is blowing. This model will give only an approximation of how fast it's blowing. After calculating the revolutions per minute it is possible to convert it to miles per hour. We will observe a transfer of energy from wind energy into mechanical energy which can be converted into light energy if necessary.

Materials

- Scissors
- 4 small paper cups (like drinking cups)
- A marking pen (any color)
- 2 strips of stiff, corrugated cardboard -- the same length
- Ruler
- Stapler
- Push pin

- Sharpened pencil with eraser on the end
- Modeling clay
- A watch that shows seconds

Procedure

- 1.) Cut off the rolled edges of the paper cups to make them lighter.
- 2.) Color the outside of one cup with the marking pen.
- 3.) Cross the cardboard strips so they make a plus (+) sign. Staple them together.
- 4.) Take the ruler and pencil and draw lines from the outside corners of where the cardboard strips come together to the opposite corners. Where the pencil lines cross will be the exact middle of the cross.
- 5.) Staple the cups to the ends of the cardboard strips; make sure the cups all face the same direction.
- 6.) Push the pin through the center of the cardboard (where the pencil lines cross) and attach the cardboard cross with the cups on it to the eraser point of the pencil. Blow on the cups to make sure the cardboard spins around freely on the pin.
- 7.) Place the modeling clay on a surface outside, Stick the sharpened end of the pencil into the clay so it stands up straight.

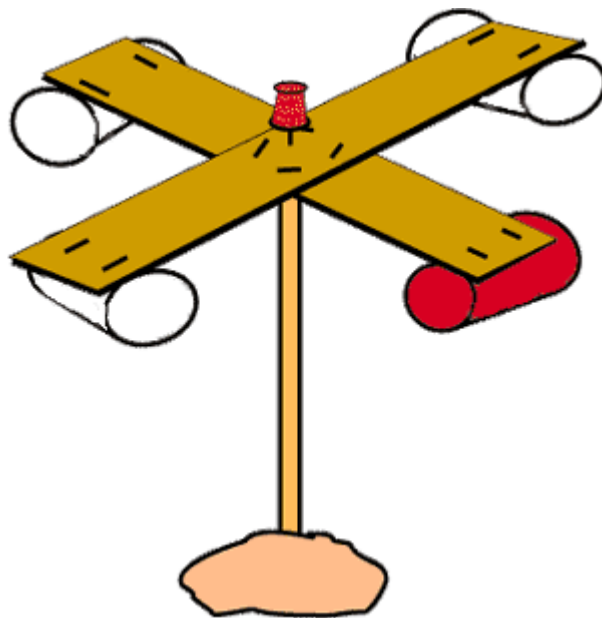

Further Investigation

- a.) What type of transfer of energy is taking place in this experiment?
- b.) Weather forecasters' anemometers convert the revolutions per minute into miles per hour (or kilometers per hour).

Using your watch, count the number of times the colored cup spins around in one minute. You are measuring the wind speed in revolutions (turns) per minute.

- *c.) How many revolutions per minute does your windmill turn?
- d.) What are some of the factors that affect the rate at which the indicator turns?
- e.) What is Mechanical energy?
- f.) What are the two states of mechanical energy?

HEAT ENERGY

Objectives:

- 1.) Heat is a form of energy.
- 2.) Heat is the least efficient form of energy
- 3.) Heat is transferred from *HOT* sources to *COOL* sinks.
- 4.) The Sun is a source of heat and the Earth is a sink for the sun.
- 5.) Practical heat transfer examples.

Information:

Heat is a form of _____. All forms of energy will end up as heat, therefore it is the _____ form of energy.

Heat energy is used all around us:

- Lights
- Cars
- Hot air balloons
- Your body

Heat can be transferred or transported (moved) from a _____ substance to a _____ substance. The *HOT* substance is called the _____ and the _____ substance is called the *SINK*. It is transferred by three different methods: conduction, convection, and radiation.

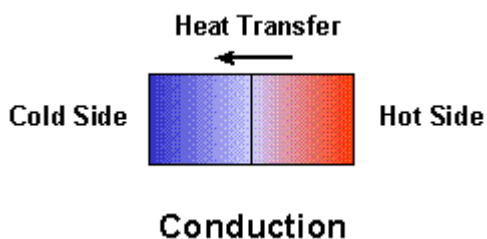

The most _____ method is conduction, which is the transfer of heat between two objects in _____. The transfer occurs as the fast-moving molecules of the hot object bump into the slower-moving molecules of the cold object. The fast molecules give up some of their _____, slowing down, and this energy goes into speeding up (and thus _____) the slow molecules.

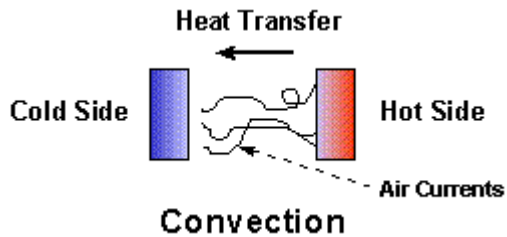

A slower method of heat transfer is _____, which occurs in _____ or _____. A cool fluid in contact with a warm solid will heat up through conduction. The warmer fluid drifts into the cooler fluid, setting up a _____.

Because material must actually be moved, convection is less efficient than conduction.

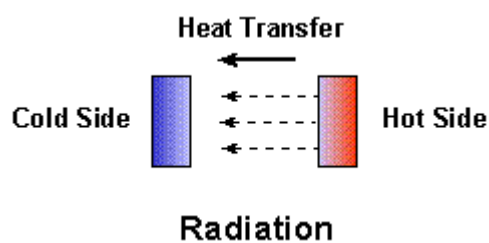

The _____ efficient method of heat transfer is radiation. In this case, heat moves through _____ without the assistance of a physical substance. This is how the Sun's _____ reaches the Earth. The radiative heat is transferred directly into a solid object, but it passes readily through transparent materials such as _____ and _____.

Demonstrations:

CONVECTIVE CURRENTS

Directions:

Fill a jar with water. Drop paper particles and give it time to settle to the bottom. Once settled, place a Bunsen burner underneath the jar and let the water boil. Observe the motion of the paper particles.

Lessons:

- The scientific principle illustrated by this experiment is that heat is transmitted by convection, which is heat transfer by the motion of the fluid by currents.
- This experiment is effective because the paper particles are settled on the bottom before boiling. While the jar of water is heated, the paper particles show the path of the currents. This shows that heat is transmitted in fluids by currents.

FIRE SCREEN - CONDUCTION

Directions:

A piece of paper, with a metal coin placed on top of it, is placed above a candle flame. The metal conducts the heat from the flame away, preventing the paper from charring at the location of the metal coin.

Lessons:

- The scientific principle which was illustrated in this experiment was that metal is a good conductor of heat.
- This demonstration is effective in demonstrating the scientific principle because a pattern of the coin is left on the paper, proving that only the place where the coin was placed remained uncharred

FLAME RETARDANT

Directions: A metal gauze is held in a flame, but the flame does not come through the screen because the heat is conducted away from the flame by the wires.

Lessons:

The scientific principle illustrated by this experiment is that metal conducts heat.

This experiment is effective because you see that the flame only burns above the wire. The wire conducts the heat away, thus preventing the gas below the screen from reaching its kindling temperature

Energy

What did you learn?

<p>Is heat a form of energy?</p>	<p>What is the definition of conduction?</p>
<p>How can you measure heat?</p>	<p>What is the definition of radiation?</p>
<p>Can energy can be created? True or False</p>	<p>Energy can be destroyed? True or False</p>

Hi there! Next up is
Nature of Matter



Nature of Matter

What do you know?

What does the light microscope do?	Do all microscopes use light as the light source? (Yes or No)
What is an atom?	What is it called when two or more molecules interact?
What are photons? (pronounced fo-tons)	Are plastics a type of polymer?

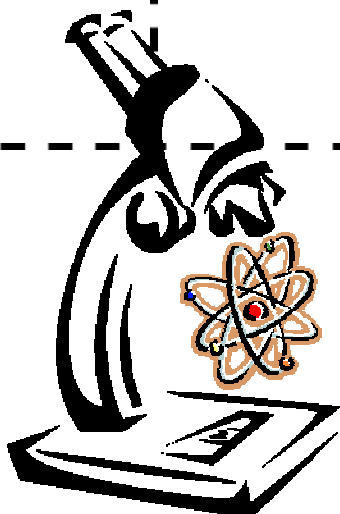

Reactions

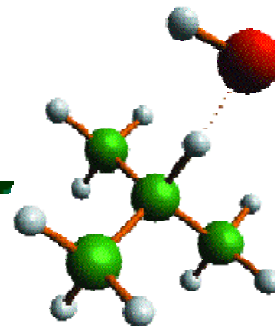

A reaction happens when two or more molecules **interact** and something happens and something changes.

What molecules are they? How do they interact? What happens? Those are all the possibilities in reactions. The possibilities are infinite.

There are physical and chemical reactions.



PHYSICAL REACTIONS

A physical reaction involves a change of states. Basically means that the substances still the same only the state changed.

Example: Melting ice changes one form of water into another form.



CHEMICAL REACTIONS

There are a few key points you should know about chemical reactions.

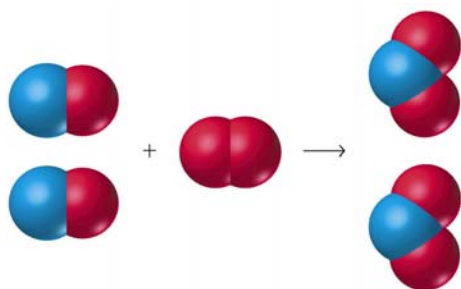

KEY POINTS

1. A **chemical change must occur**. You start with one compound and turn it into another.

Example: A steel garbage can rusting is a chemical reaction. That rusting happens because the iron in the metal combines with oxygen in the atmosphere.



2. A reaction could include ions, molecules, or pure atoms.

If you put pure hydrogen gas and pure oxygen gas in a room, they can be involved in a reaction. The slow reaction will have the atoms bonding to form water very slowly.



If you were to add a spark, those gases would create a reaction that would result in a huge explosion.



Web References:

www.Chem4kids.com
<http://www.roxie.org/books/shoulders/glossary.html>



The Messy Lab

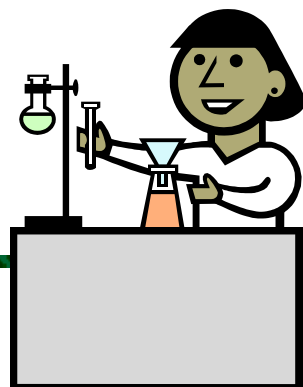

In this lab, we will be traveling around the room doing different experiments. The class will be divided into 4 groups and each group will rotate into each station. You will perform all of the experiments and then answer the questions in your book before going on to the next station. Everyone in your group must complete the questions before that group is allowed to move on. You are allowed to work as a team to find the answers to the questions. Now, get going!

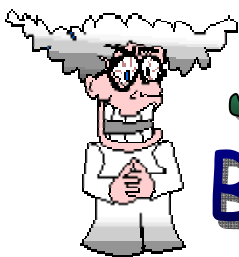

Station 1: Bubbles Reaction

Objective: To observe a chemical reaction and its product.

Conclusions:

1. What did you observe? _____

2. If you continue to add more and more baking soda, do you think you will continue to get more and more bubbles? Why or why not? _____



Station 2: GLUE INVENTION

Objective: In this activity, you can mix your ingredients in any amounts that you like. You might want to make a few different combinations to see which works best, so don't use up all your ingredients on the first try. Have fun and may the stickiest glue win!

Conclusions:

3. What did you observe? _____

4. Which combination of ingredients made the stickiest glue? _____

Station 3: Wacky Polymers



What are Polymers?

Polymers are long chains of chemicals found almost everywhere in nature. Certain types of polymers called proteins make up hair, feathers, cartilage, and other body parts. Another polymer called cellulose makes up wood, leaves, and other plant parts. Polymers can also be made in factories. Plastic is good example of this type of polymer.

Polymers are formed by *chemical reactions* in which a large number of molecules called monomers are joined sequentially, forming a chain.

Conclusions:

5. What did you observe? _____

6. Does it stretch, wiggle, or bounce? _____

7. Can it be molded? _____

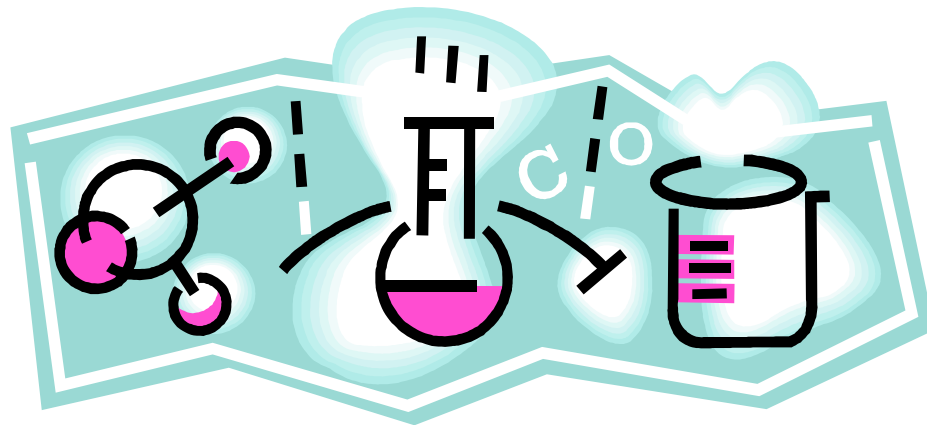

Name _____

Date _____

Station 4:



Bubbularium

Objective:

To observe how white light reflects from a soap film

Conclusions:

8. Watch the colors. How many do you see? _____

9. If you watch a bubble for a few minutes, do the colors change?

10. What colors do you see right before the bubble pops?

11. Do you ever see black and white polka dots? _____



Electron Light

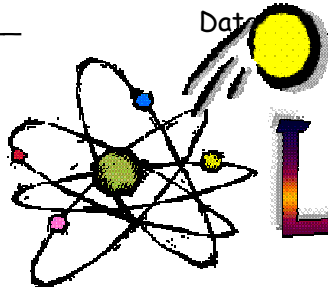

ATOMS = BUILDING BLOCKS

Atoms are the basis of chemistry. They are the basis for everything in the Universe. You should start by remembering that matter is composed of atoms.

Take a look at the picture to the right. You have a basic atom. There are three pieces to an atom. There are electrons, protons, and neutrons. That's all you have to remember. Three things! As you know, there are over 100 elements in the periodic table. The thing that makes each of those elements different is the number of electrons, protons, and neutrons. The protons and neutrons are always in the center of the atom. Scientists call the center of the atom the nucleus. The electrons are always found whizzing around the center in areas called orbitals.

IT'S LIKE THIS...

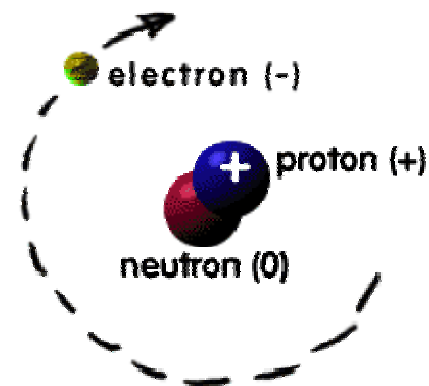

ELECTRONS ALL OVER

As you know, electrons are always moving. They spin very quickly around the nucleus of an atom. As the electrons spin, they can move in any direction, as long as they stay in their shell. Any direction you can imagine - upwards, downwards, or sideways - electrons can do it. The atomic shell or orbital is the distance from the nucleus that the electron spins. If you are an electron in the first shell you are always closer to the nucleus than the electrons in the second shell.



ORBITAL BASICS

Let's cover some basics of atomic orbitals.

1. A shell is sometimes called an orbital or energy level.
2. Shells are areas that surround the center of an atom.
3. The center of the atom is called the nucleus.

4. Electrons live in something called shells.
5. Each of those shells has a name.

There are a couple of ways that atomic orbitals are named. You may have heard of the SPDF system before. Chemists also use letters to name the orbitals around a nucleus. They use the letters "k,l,m,n,o,p, and q". The "k" shell is the one closest to the nucleus and "q" is the farthest away.



Not all shells hold the same number of electrons. For the first eighteen elements, there are some easy rules. The k-shell only holds two electrons. The l-shell only holds eight electrons. The m-shell only holds eight electrons (for the first eighteen elements). The m-shell can actually hold up to 18 electrons as you move farther along the periodic table. The maximum number of electrons you will find in any shell is 32.

So, what do atoms have to do with light?

You'll find out soon enough. First, let's do a simulation of an atom.

FIRST) With your partner, collect the necessary materials.

SECOND) Sit patiently until everyone is ready to begin.

THIRD) Follow along as we build an atom together.

Now that you know what atoms are like, let's discuss how this relates to light. Remember, atoms have neutrons, protons and electrons. An electron has a natural orbit that it occupies, but if you **energize** an atom you can move its electrons to higher orbitals. A photon of light is produced whenever an electron in a higher-than-normal orbit falls back to its normal orbit. During the fall from high-energy to normal-energy, the electron emits a photon -- a packet of energy -- with very specific characteristics. The photon has a frequency, or color, that exactly matches the distance the electron falls.

So, what is light? Einstein said that light was made up of a stream of energy packets called **photons**.

Questions

1. What are the three parts of an atom? _____

2. In your simulation, describe what materials you used and what they represented. _____

3. How are photons produced in an atom? _____

4. How do light particles (photons) travel? _____

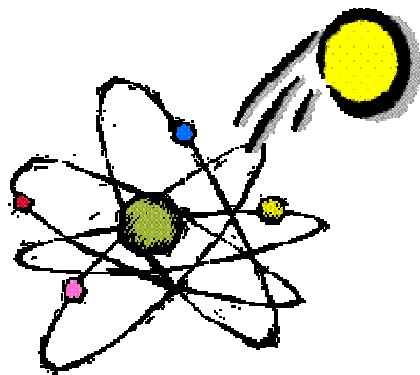

Do Try This at Home

Here is an absorption experiment that you can try at home: First, make a blue cellophance covered flashlight. Take blue cellophane and wrap it around the bulb end of the flashlight. Take a banana (no need to peel it) and the prepared flashlight and go into a dark room. Shine the blue light on the banana. Shine the blue light on the banana.



What color do you think it should be? What color is it?

If you shine blue light on a yellow banana, the yellow should absorb the blue frequency; and, because the room is dark, there is no yellow light reflected back to your eye. Therefore, the banana appears black.



Here's the explanation. So, if you had three paints or pigments in magenta, cyan and yellow, and you drew three overlapping circles with those colors, as shown in the figure below, you would see that where you have combined magenta with yellow, the result is red. Mixing cyan with yellow produces green, and mixing cyan with magenta creates blue. Black is the special case in which all of the colors are absorbed. You can make black by combining yellow with blue, cyan with red or magenta with green. These particular combinations ensure that no frequencies of visible light can bounce back to your eyes.

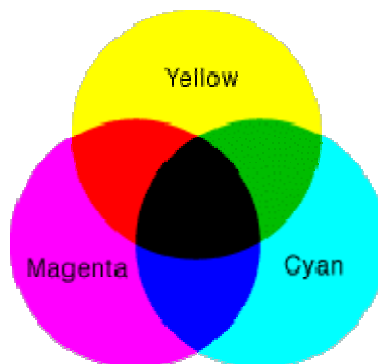



Light is a form of energy, which can be emitted through a variety of processes. These processes include:

- Incandescence - The emission of light due to heat (as in an ordinary light bulb or a gas lantern)
- Fluorescence and phosphorescence - The emission of light in response to radiation energy (as in a fluorescent light bulb or a television)
- Laser generation - The concentrated emission of light using stimulated emission

All these processes work on the same basic principle: An outside source of energy excites atoms, causing them to release particles of light called photons. When you burn something, for example, heat energy causes the atoms that make up the material to speed up. When the atoms speed up, they collide with each other with greater force. If the atoms are excited enough, the collisions will transfer energy to some of the atom's electrons. When this happens, an electron will be temporarily boosted to a higher energy level (farther away from the atom's nucleus). When it eventually falls back down to its original level (closer to the nucleus), it releases some of its energy in the form of light photons.

Ever wonder how a light stick works? It uses a **chemical reaction** to excite the atoms in a material. This chemical reaction is set off by mixing multiple **chemical compounds**. Compounds are substances made up of atoms of different elements, bonded together in rigid structure. When you combine two or more compounds, the various atoms may rearrange themselves to form new compounds. Depending on the nature of the compounds, this reaction will cause either a release of energy or absorption of energy.

Station 1: Cool Blue Light

Follow the directions given at the station. As a team, complete the following questions.

After reading the directions and objective, what is your hypothesis?

What did you observe? _____

Describe the light, why is it "cool"? _____

Station 2: The Bright Bleach Light

Follow the directions given at the station. As a team, complete the following questions.

After reading the directions and objective, what is your hypothesis?

What did you observe? _____

How is it different from the experiment at station 1? _____

Station 3: Dirty Copper

Follow the directions given at the station. As a team, complete the following questions.

After reading the directions and objective, what is your hypothesis?

What did you observe? _____

Which penny worked best and why do you think it worked best? _____

Station 4: Hot versus Cold

Follow the directions given at the station. As a team, complete the following questions.

After reading the directions and objective, what is your hypothesis?

What did you observe? _____

How did the change in temperature affect the reaction? _____

The Light Microscope

an Important Tool for the Young Scientist



Purpose:

1. The student will learn the proper procedure for operating a light microscope.
2. The student will also learn about heterogeneous and homogeneous mixtures, and how the microscope is a tool used to classify these substances.

What is a *microscope*?



microscope
light bulb

The microscope (*micro* = small, *scope* = to view) is a tool used to enlarge, or magnify, objects that are too small to be seen with your eyes alone. The microscope we will be learning about uses light from a light bulb to illuminate (light up) the sample. Because it uses light, it is also called a light microscope.

Do all microscopes use light?

There are other types of microscopes that do not use light. Two examples are the Scanning Electron Microscope and the Transmission Electron Microscope. These use electrons to obtain images of the samples at a much higher magnification than light microscopes.

Why are microscopes so important?

The microscope is an important tool for students, scientists, and researchers who are studying very small objects. For example, microscopes are used to study different types of cells. This has enabled scientists to come up with new medicines and therapies to treat various illnesses, such as cancer.

What are the parts of the microscope?

Let's investigate!

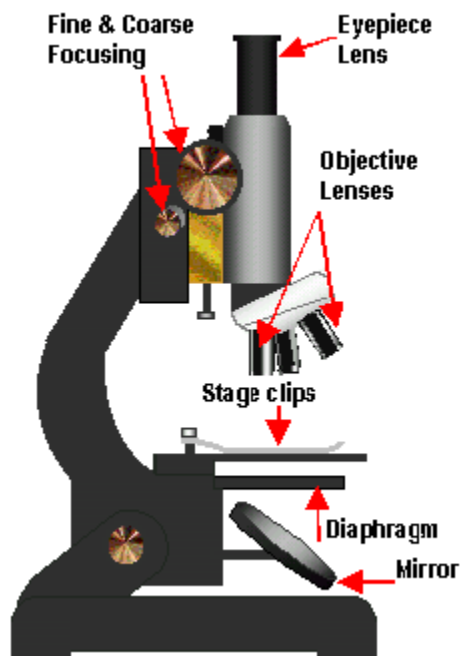

Above: The light microscope and its main components.

Fill in the blanks:

1. The eyepiece is where you position your eyes so you can look at your _____ while it is being magnified.
2. The arm attaches the _____ to the base of the microscope.
3. The coarse and fine focus knobs let you _____ the image if it is blurry.
4. By varying the size of the diaphragm opening, the amount of _____ illuminating the sample is changed.
5. The stage is where you _____ your sample.
6. The lens magnifies the sample so that it looks larger when you look through the _____.
7. The microscope uses a mirror or a light bulb as a _____ source to illuminate the sample.

Now it's time to use the microscope.

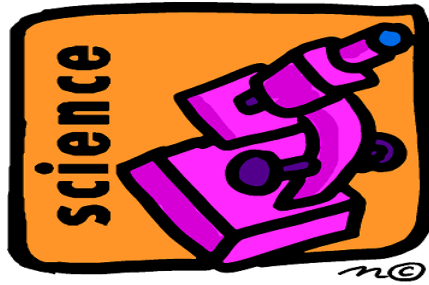

Procedure:

- 1) Turn the microscope on- this makes the light source turn on
- 2) Set the microscope to the lowest magnification
- 3) Adjust the image with the coarse adjust knob first, and then use the fine adjust knob if necessary

Observations: _____

Now we are ready to learn about *heterogeneous* and *homogeneous mixtures*, and how microscopes help us to tell the difference between the two. First, we need to learn a few vocabulary terms:

What is a mixture?

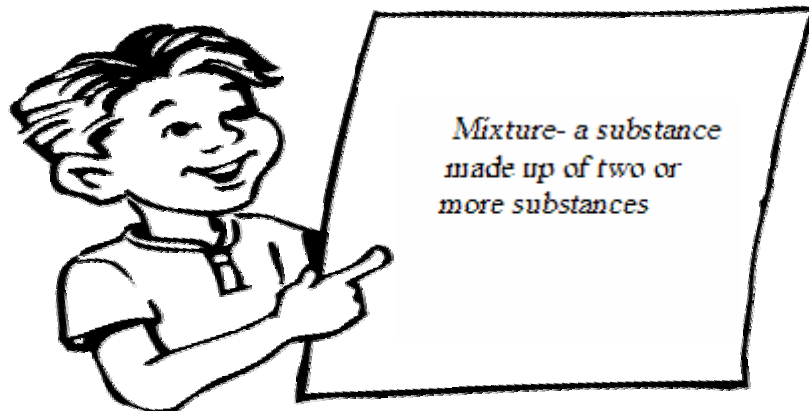

What is a heterogeneous mixture?



A heterogeneous mixture does not look the same throughout. One example is vegetable soup.

What is a homogenous mixture?

A homogenous mixture looks the same throughout. One example is hot tea with sugar. Because the sugar dissolves, you cannot see it in the tea.





Now that we know their definitions, let's investigate the difference between these two types of mixtures under a microscope! In the next section, you will make a microscope slide out of clear tape. Then you will view 5 different samples under the microscope.

From your observations, you will conclude whether the sample is heterogeneous or homogenous.

Materials:

- Clear tape
- Ruler
- Scissors
- Samples (sugar, salt and pepper, cornstarch, sand, and coffee)

1) To make a slide, measure out 3 inches of tape and tear off.

2) Next, fold the ends as in the picture to the right.



3) Sprinkle a few grains of what you would like to magnify onto the sticky part of the tape.

4) Now place your sample onto the stage of the microscope. You are now ready to view the sample! Make sure to write down your observations in the table below:

Name _____

Date _____

SAMPLE (sugar, salt and pepper, cornstarch, sand, or coffee)	OBSERVATIONS- conclude whether the sample is heterogeneous or homogeneous

Nature of Matter

What do you know?

What does the light microscope do?	Do all microscopes use light as the light source? (Yes or No)
What is an atom?	What is it called when two or more molecules interact?
What are photons? (pronounced fo-tons)	Are plastics a type of polymer?

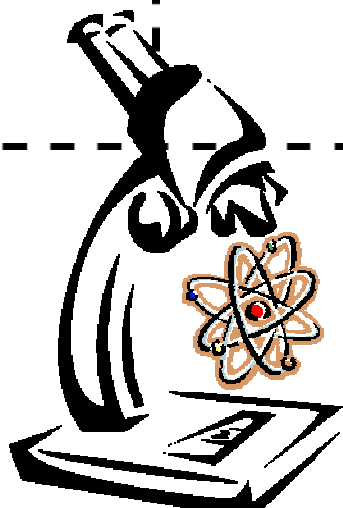

Now we get to learn about
Processes of Life!

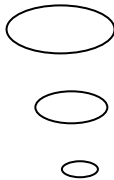

Processes of Life

What do you know?

When are there hurricanes in the United States? Choose one:
Fall, Spring, Summer, or Winter

Is it possible to predict the path of a hurricane? Yes or No

Does the sun help plants grow?

What are cells?

Is the sun harmful to your skin?

What is one way to protect your skin from the sun?



EXPERIMENT: RATE OF PHOTOSYNTHESIS

INTRODUCTION:

Photosynthesis is the process by which plants use energy from sunlight to convert water and carbon dioxide into oxygen and glucose. This process occurs in the chloroplast of the plant. The amount of light, the carbon dioxide supply, the temperature, the water supply, and the availability of minerals are the most important environmental factors that directly affect the rate of photosynthesis in land plants.

OBJECTIVE:

MATERIALS:

1 - Light Source	1 - test tube	1 - water plant
1 - Beaker or clear cup	1 - mini funnel	1 - ruler
1 - pencil	1 - cup of water	
1- stop watch or timer		

HYPOTHESIS:

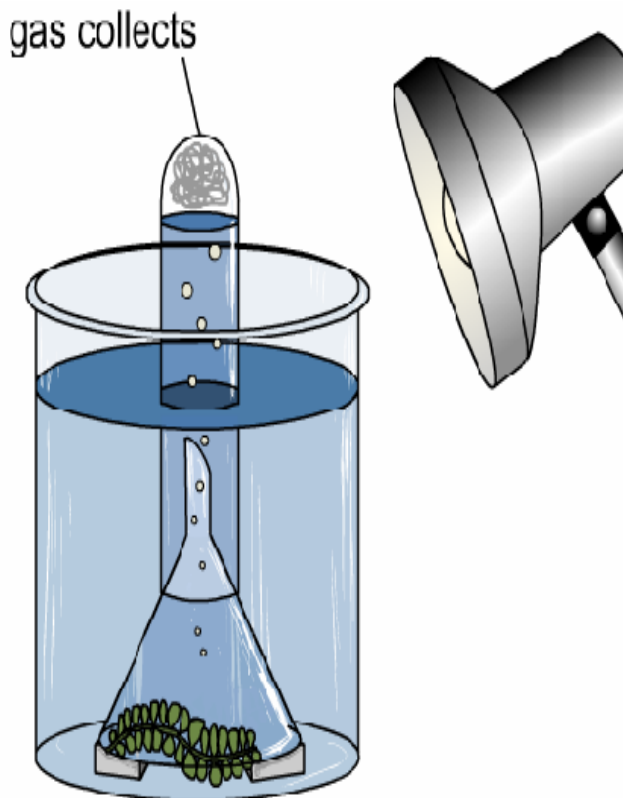
EXPERIMENTAL SETUP:

1. Place water plant at bottom of beaker
2. place blocks on both sides of water plant
3. Put funnel over water plant. *Be sure to rest funnel on blocks.*
4. Insert test tube over neck of funnel
5. Slowly pour in cup of water until funnel is completely submerged
6. Using a ruler position the light source at specified distances listed in table.
7. Measure bubbles every minute for each distance

RESULTS:

Insert the information in the table then plot your data results. *Don't forget to label data chart properly.*

Distance between lamp and plant (cm)	Number of bubbles seen per minute
0	
5	
10	
20	
25	
30	
35	
40	

Name _____

Date _____

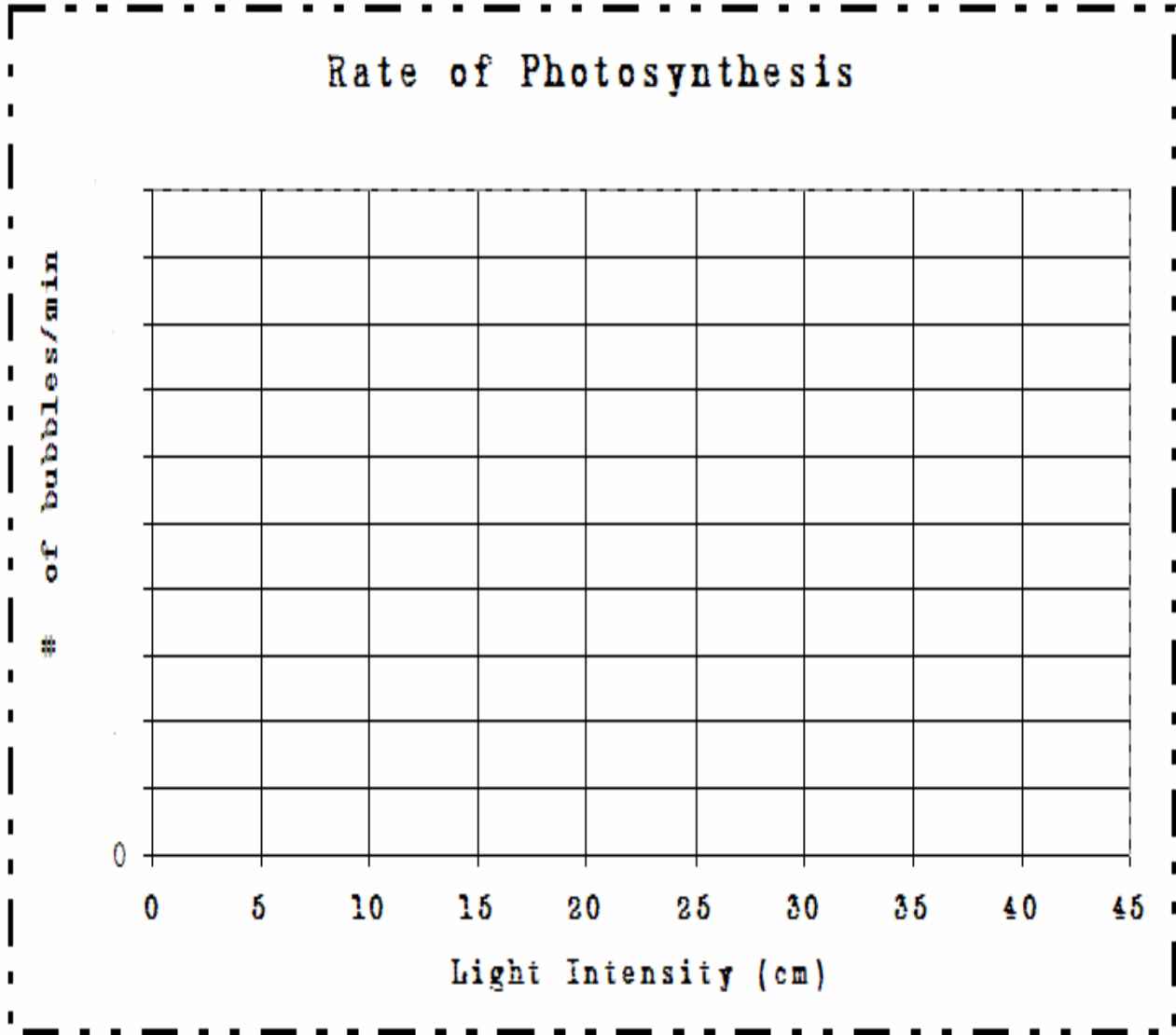



EXPERIMENT: MAPPING HURRICANES



Introduction:

Hurricane Classification

Using the Sapphir-Simpson method hurricanes are categorized based on their wind speeds, pressure, and potential to cause damage.

Category	Winds (mph)	Damage
1	74-95 mph	minimal damage
2	96-110 mph	significant damage
3	111-130 mph	severe damage
4	131-155 mph	extreme damage
5	>155 mph	catastrophic damage

The official hurricane season for the United States is from June 1 to November 30, but hurricanes can happen any time of the year if atmospheric conditions are right. Hurricanes are named by the National Weather Service. Some [past hurricanes](#) have been [named](#): Wilma, Andrew, Ivan, and Katrina.

MATERIALS:

- Pencil
- Markers
- Hurricane Track Chart

Experimental Setup:

Using the Hurricane track chart develop a model of the hurricane formation.

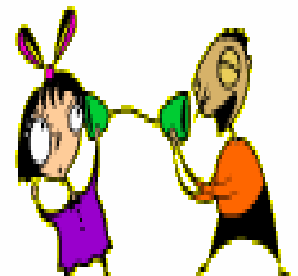

Cells & DNA

Cells: All living organisms are made up of cells
"building blocks of life"

DNA - Deoxyribose nucleic acid; double helix shaped molecules located in the cell nucleus that provide the code for a living organism to grow and function.

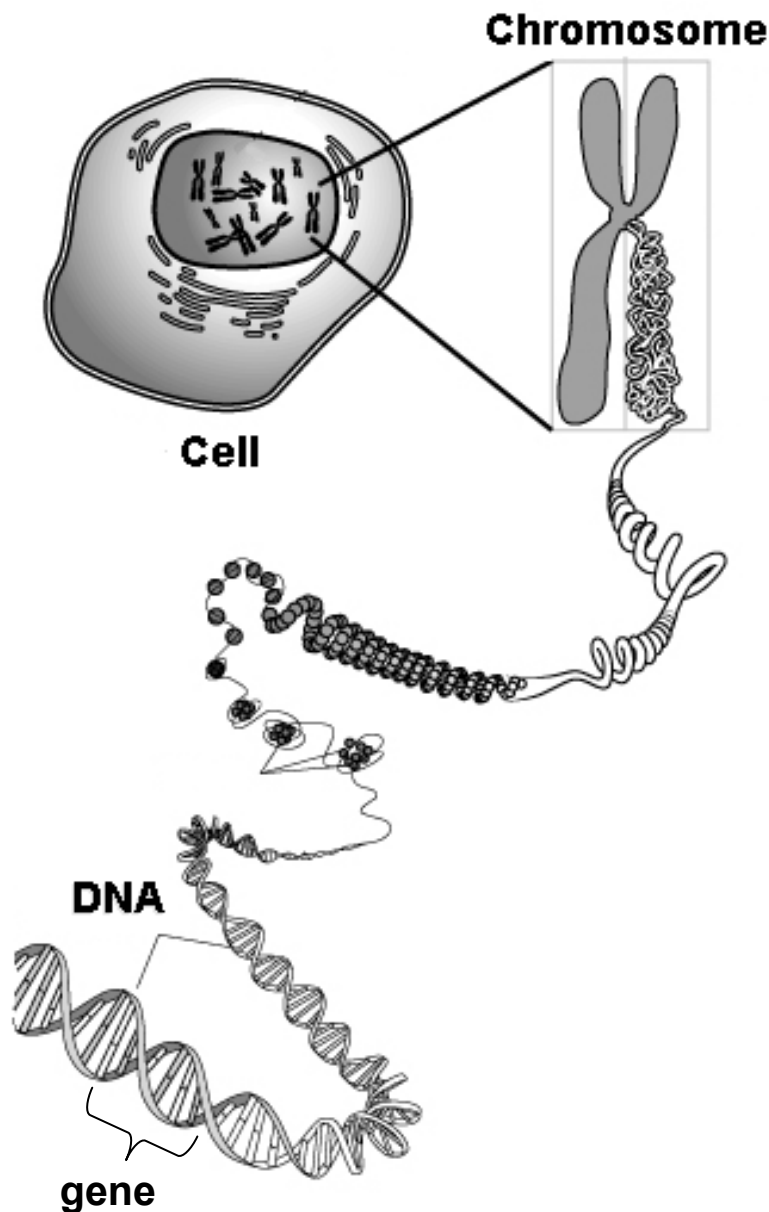

Build YOUR DNA and Eat it too!



Background:

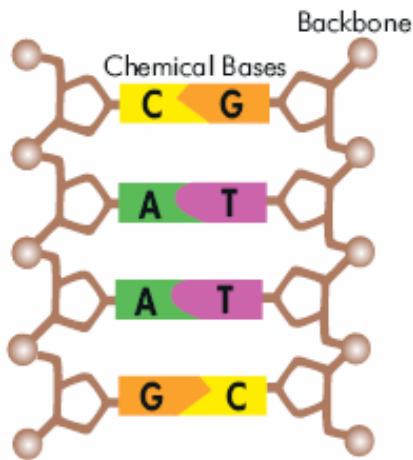

When isolated from a cell and stretched out, DNA looks like a twisted ladder. This shape is called a double helix. The sides of the DNA ladder are called the backbone and the steps (also called rungs) of the ladder are pairs of small chemicals called bases. There are four types of chemical bases in DNA: Adenine (A), Cytosine (C), Guanine (G), and Thymine (T). They form pairs in very specific ways: Adenine (A) always pairs with Thymine (T) and Cytosine (C) always pairs with Guanine (G).

Objective:

Your task is to use the following materials and procedure to construct an edible model of DNA. When you are finished, use toothpicks and tape to label one of each of the chemical bases.

Materials:

- 2 pieces of licorice
- 12 toothpicks
- 9 pink marshmallows
- 9 yellow marshmallows
- 9 green marshmallows
- 9 orange marshmallows
- 5 paperclips
- Masking Tape



Procedure:

1. Choose one of the sequences below.

Adenine (A) = Green	
Thymine (T) = Pink	
Cytosine (C) = Yellow	
Guanine (G) = Orange	

Sequence 1: T A C G T A T G A A A C

-or-

Sequence 2: T G G T T T A G A A T T

2. Assemble one side of your DNA molecule. A piece of licorice will form the backbone and marshmallows will be the chemical bases. Place a marshmallow on the end of a toothpick so that the point of the toothpick goes all the way through. Anchor the toothpick into the licorice backbone. Refer to the table above to choose the correct color marshmallow to represent the chemical bases in your sequence.

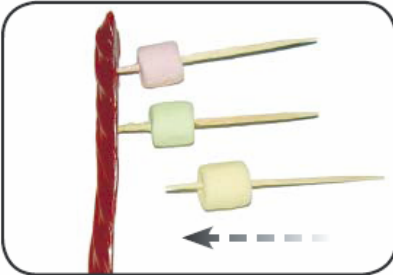

Place a marshmallow on the end of a toothpick so that the point of the toothpick goes all the way through. Anchor the toothpick into the licorice backbone. Refer to the table above to choose the correct color marshmallow to represent the chemical bases in your sequence.

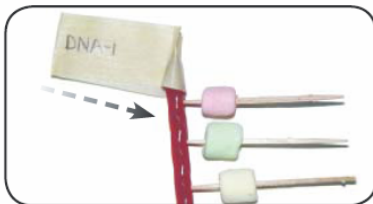

3. Label the backbone. With a marker or pen and masking tape, label your licorice backbone "DNA- 1" or "DNA-2" depending on which sequence you used. Write the label on the left end of the licorice.

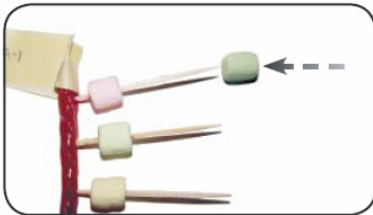

4. Match the chemical base pairs. Place the color marshmallow for the matching chemical base on the other end of each toothpick. Remember that A always pairs with T and C always pairs with G!

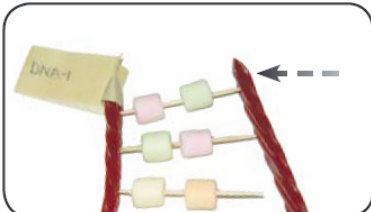

5. Complete your DNA model. Attach the other backbone so your model looks like a ladder.

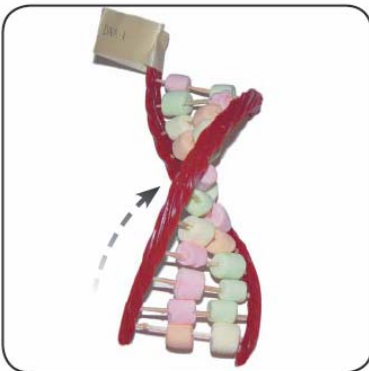

6. Twist your DNA model. Carefully twist your DNA molecule so that it looks like a double helix.

7. Label your model. Make flags to label the parts of your DNA out of paper clips and tape. Label one of each of the following: Adenine, Thymine, Cytosine, Guanine, and Backbone. **Make sure your chemical base pairs are correct!**

Web References:

Activity and pictures taken from:
<http://gslc.genetics.utah.edu>



Skin Cancer

Cancer: A disease characterized by the rapid and uncontrolled growth of mutant cells that will form malignant tumors.

Sometimes cells keep dividing and growing without normal controls, causing an abnormal growth called a tumor.

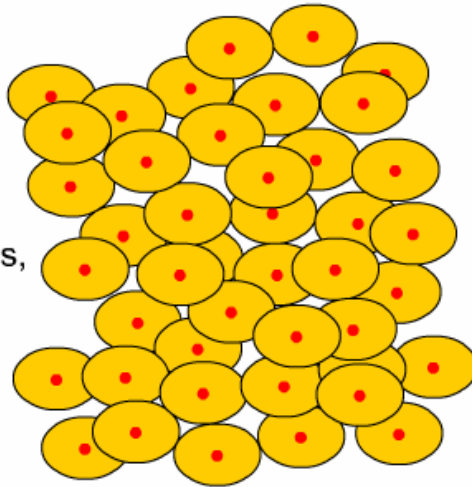

Skin Cancer: Skin cancer is a disease in which cancer (malignant) cells are found in the outer layers of your skin. Your skin protects your body against heat, light, infection, and injury. It also stores water, fat, and vitamin D.

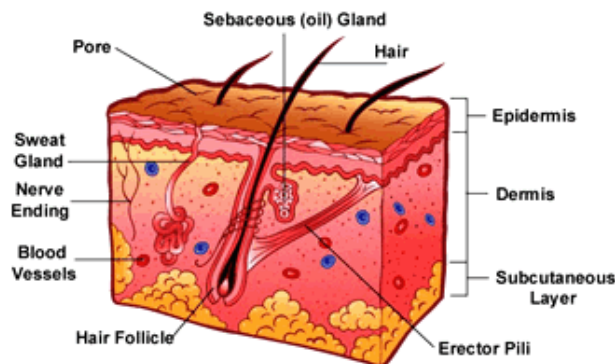

There are several types of cancer that start in the skin. The most common are basal cell cancer and squamous cell cancer.

What Causes Skin Cancer?

Heredity

If there is a history of skin cancer in your family, you are probably at a higher risk.

Sunburn and Sunlight

Very simply, sunburn and [UV light](#) can damage your skin, and this damage can lead to skin cancer.

Environment

The level of UV light today is higher than it was 50 or 100 years ago. This is due to a reduction of ozone in the earth's atmosphere (the Ozone Hole).

Ozone serves as a filter to screen out and reduce the amount of UV light that we are exposed to. With less atmospheric ozone, a higher level of UV light reaches the earth's surface.

Other influencing factors include [elevation, latitude, and cloud cover](#).

Ultra Violet light is stronger as elevation increases.

The thinner atmosphere at higher altitudes cannot filter UV as effectively as it can at sea level.

The rays of the sun are also strongest near the equator, as you might guess.

In the United States, for example, skin cancer is more common in Texas than it is in Minnesota, where the sun is not as strong. Worldwide, the highest rates of skin cancer are found in South Africa and Australia, areas that receive high amounts of UV radiation.

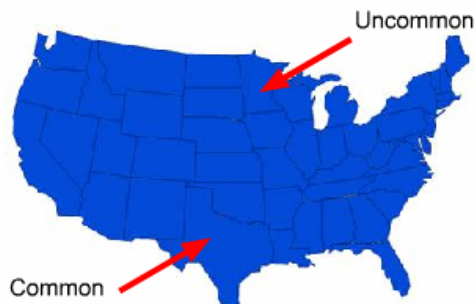

Are there precautions that will reduce my risk?

- Minimize your exposure to the sun at midday and between the hours of 10:00AM and 3:00PM.



- Apply [sunscreen](#) with at least a SPF-15 or higher, to all areas of the body which are exposed to the sun.
- Reapply sunscreen every two hours, even on cloudy days. Reapply after swimming or perspiring.
- Wear clothing that covers your body and shades your face. (Hats should provide shade for both the face and back of the neck.)
- Avoid exposure to UV radiation from [sunlamps or tanning parlors](#).
- Protect kids. Do not use sunscreen on children under 6 months of age.



Remember, skin cancer is very slow to develop. The sunburn you receive this week may take 20 years or more to become skin cancer.

Protect YOURSELF!!!

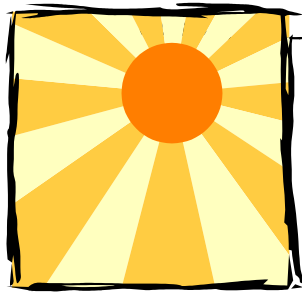

Date _____

UV Index Exploration!

Objective:

Your task is to investigate the UV index of different cities in the United States and make suggestions on how to protect themselves from UV radiation.

Materials:

Internet access: <http://www.epa.gov/sunwise/uvindex.html#lookup>
Sunscreen SPF 15 or higher

Additional information:

http://www.nlm.nih.gov/medlineplus/tutorials/skincancerandmelanoma/htm/_yes_50_no_0.htm

Procedure:

1. Look up for the UV-indexes of the following cities in the US
 - a. Mobile, Alabama
 - b. Phoenix, Arizona
 - c. Charleston, South Carolina
 - d. Los Angeles, California
 - e. Dallas, Texas
 - f. New York City, New York
 - g. Tampa, Florida
 - h. Detroit, Michigan
 - i. Minneapolis, Minnesota
 - j. Milwaukee, Wisconsin
 - k. Honolulu, Hawaii
 - l. Cheyenne, Wyoming
2. Choose your favorite city (optional)
3. Write your result on the following table and graph it.

4. Pick the lowest and highest UV-index cities and colored the UV meters below. Also, include Tampa, Florida in this study.

UV INDEX		
The higher the UV Index the greater the need for skin and eye protection.		
Index Number	Exposure Level	Color Code
0-2	Minimal	Blue
3-4	Low	Green
5-6	Moderate	Yellow
7-9	High	Orange
10+	Very High	Red

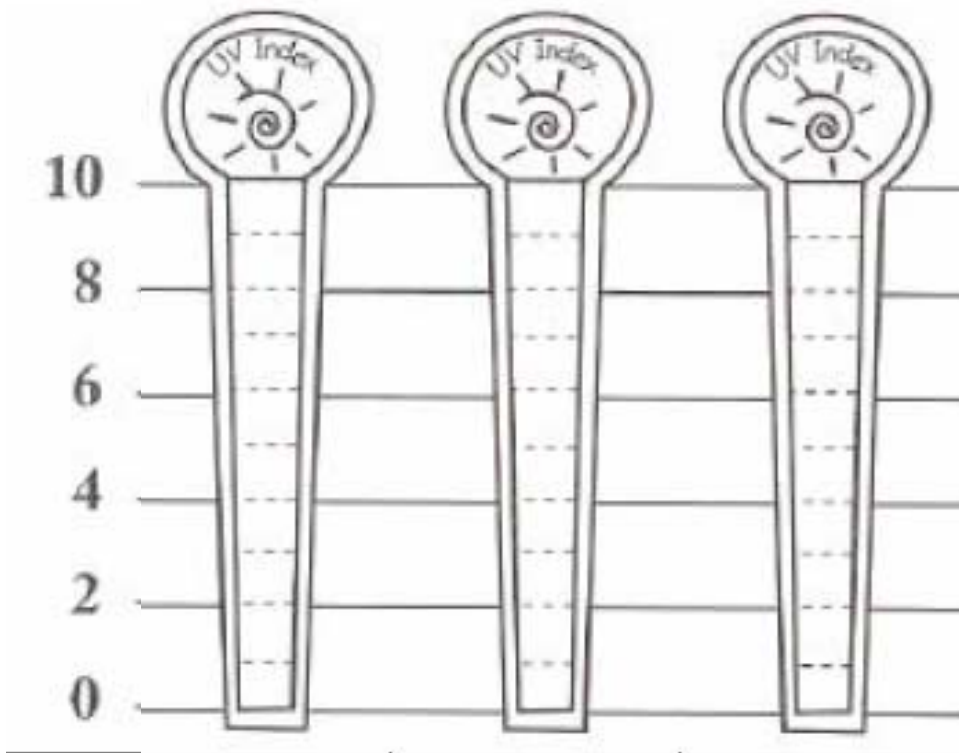

5. Describe the precautions needed for each city based on UV index
- -
 -

Web References:

<http://www.epa.gov/sunwise/uvindex.html#lookup>
<http://www.maui.net/~southsky/introto.html#causes>
<http://www.epa.gov/sunwise/becoming.html>

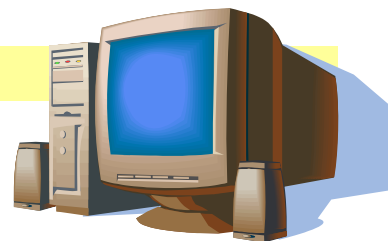

Processes of Life

What did you learn?

**When are there hurricanes in the United States? Choose one:
Fall, Spring, Summer, or Winter**

Is it possible to predict the path of a hurricane? Yes or No

Does the sun help plants grow?

What are cells?

Is the sun harmful to your skin?

What is one way to protect your skin from the sun?

